



Delivering on the Accelerated Agricultural Growth and Transformation for Shared Prosperity and Improved Livelihoods in Africa

TECHNICAL NOTES

for preparing the 2017 African Agriculture Transformation Scorecard on implementing Commitments of the June 2014 AU Heads of State Malabo Declaration

The 2017 Progress Report on African Agricultural Transformation for implementing the Malabo Declaration is due at the January 2018 AU Assembly of Heads of State and Government

Draft March 2017

Introduction

The African Union (AU) Commission is preparing the 1st Report on the implementation of the June 2014 AU Assembly Declaration on the Malabo Commitments for agricultural transformation in Africa; a report which is due for the January 2018 AU Assembly.

The Report is currently being prepared and will be a compilation of data expected from the 55 AU Member States that are being trained to carry out self-assessments and provide their individual progress report for achieving each target set in the Malabo Declaration.

Member states are preparing their report using the *Country Reporting Template* and *Technical Guidelines* that are developed in line with the 7 performance themes of the Malabo Declaration, where 23 performance categories and 43 indicators have been prioritized to be tracked and reported on by member states for the 2017 reporting round.

The seven (7) performances themes of the Malabo Declaration include:

Theme 1- Commitment to CAADP process

Theme 2- Investment finance in Agriculture

Theme 3- Ending Hunger

Theme 4- Eradicating Poverty through Agriculture

Theme 5- Intra-African Trade in Agriculture commodities

Theme 6- Resilience to Climate Variability

Theme 7- Mutual Accountability for Actions and Results

Agreement reached by the leadership of the AU Commission is to evaluate the progress made by individual member state in the form of *Balanced Scorecard* and to come up with the *African Agricultural Transformation Scorecard*, using appropriate methods to benchmark country performance in achieving targets set in the Malabo Declaration.

Benchmarking methods are metric methods that bring accuracy, rightness and fairness in evaluating progress for achieving a specific goal for which smart targets and corresponding indicators have been designed and agreed upon. The methods can help to get a *Balanced Scorecard that enables* peer-to-peer metric comparison of performances in order to stimulate continuous improvement of interventions towards the common agreed targets. In this case, the clarity of the benchmarking model seeks mainly to allow Member States to see how their performance is measured, and to search for best practices in order to overcome identified challenges, while reinforcing the culture of continuous improvement and providing sense of urgency in achieving agriculture Sector goals for Africa.

These **2017 Technical Notes**, while recalling methods used in the *AU's Malabo Biennial Review Technical Guidelines* to calculate each performance indicator, provide as well further details on the methods used to calculate the Performance Indices and reference points for performance measurement that permit to set a right score in the *Balanced Scorecard*, accordingly with the agreed weighting systems.

In line with the performance structure set for the Biennial review exercise, the models in this document, provide: the **I-score** which is the score attributed to the performance Indicator; the **C-score** which is the combined score of the performance Category; the **T-score** which is the combined score of the performance Theme; and the **O-score** which is the Overall score in achieving the Malabo declaration. The milestone and the Benchmark as appeared in the document, are respectively the current values (minimum) of the indicator and the score, for the country to be on track for achieving the target set for the target year.

These Technical Notes will serve as basis for the design of the database for country data compilation to generate the 2017 Malabo Scorecard.



ADOPTED WEGHTING SYSTEM

**for designing the balanced African Agricultural Transformation
Scorecard: *The Performance Structure.***



Weighting Systems for designing the Balanced Scorecards on progress made for implementing the June 2014 Malabo Declaration on Agriculture transformation in Africa

Performance Theme			Performance Category			Performance Indicators		
No.	Item	T-weight	No.	Item	C-weight	No.	Item	I-weight
1	Commitment to CAADP Process	14.3%	PC 1.1	Country CAADP Process	4.8%	1.1	CAADP Process Completion Index (CAADPPro)	4.8%
			PC 1.2	CAADP based Cooperation, Partnership & Alliance	4.8%	1.2	Existence of, and Quality of multi-sectorial and multi-stakeholder coordination body (Qc)	4.8%
			PC 1.3	CAADP based Policy & Institutional Review/ Setting/ Support	4.8%	1.3	Evidence-based policies, supportive institutions and corresponding human resources (EIP)	4.8%
2	Investment Finance in Agriculture	14.3%	PC 2.1	Public Expenditures to Agriculture	3.6%	2.1i	Public agriculture expenditure as share of total public expenditure (tPAE)	1.2%
						2.1ii	Public Agriculture Expenditure as % of agriculture value added (PAEAgVA)	1.2%
						2.1iii	ODA disbursed to agriculture as % of commitment (ODA)	1.2%
			PC 2.2	Domestic Private Sector Investment in Agriculture	3.6%	2.2	Ratio of domestic private sector investment to public investment in agriculture (tDPrPb)	3.6%
			PC 2.3	Foreign Private Sector Investment in Agriculture	3.6%	2.3	Ratio of foreign private direct investment to public investment in agriculture (tFPrPb)	3.6%
			PC 2.4	Access to finance	3.6%	2.4	Proportion of men and women engaged in agriculture with access to financial services (tAgFs)	3.6%
Ending Hunger		14.3%	PC 3.1	Access to Agriculture inputs and technologies	2.9%	3.1i	Fertilizer consumption (kilogram of nutrients per hectare of arable land), (Fz)	0.5%
						3.1ii	Growth rate of the size of irrigated areas from its value of the year 2000 (RIIA)	0.5%
						3.1iii	Growth rate of the ratio of supplied quality agriculture inputs (seed, breed, fingerlings) to the total national inputs requirements for the commodity (tAgI)	0.5%
						3.1iv	Proportion of farmers having access to Agricultural Advisory Services (FAGAS)	0.5%
						3.1v	Total Agricultural Research Spending as a share of AgGDP (tTARS)	0.5%
						3.1vi	Proportion of farm households with ownership or secure land rights (tHhSL)	0.5%
			PC 3.2	Agricultural Productivity	2.9%	3.2i	Growth rate of agriculture value added, in constant US dollars, per agricultural worker (tAgW)	1.0%
						3.2ii	Growth rate of agriculture value added, in constant US dollar, per hectare of agricultural arable land (tAgL)	1.0%
						3.2iii	Growth rate of yields for the 5 national priority commodities, and possibly for the 11 AU agriculture priority commodities (tY)	1.0%
			PC 3.3	Post-Harvest Loss	2.9%	3.3	Reduction rate of Post-Harvest Losses for (at least) the 5 national priority commodities, and possibly for the 11 AU agriculture priority commodities (tPHL).	2.9%
			PC 3.4	Social Protection	2.9%	3.4	Budget lines (%) on social protection as percentage of the total resource requirements for coverage of the vulnerable social groups (tSP)	2.9%
			PC 3.5	Food security and Nutrition	2.9%	3.5i	Prevalence of stunting (% of children under 5 years old) (St)	0.5%
						3.5ii	Prevalence of underweight (% of children under 5 years old) (Uw)	0.5%
						3.5iii	Prevalence of wasting (% of children under 5 old) (W).	0.5%
						3.5iv	Proportion of the population that is undernourished (% of the country's population) (U)	0.5%
						3.5v	Growth rate of the proportion of Minimum Dietary Diversity-Women (tMDDW)	0.5%
			3.5vi	Proportion of 6-23 months old children who meet the Minimum Acceptable Diet (MAD)	0.5%			

Performance Theme			Performance Category			Performance Indicators			
No.	Item	T-weight	No.	Item	C-weight	No.	Item	I-weight	
4	Eradicating Poverty through Agriculture	14.3%	PC 4.1	Agricultural GDP and Poverty Reduction	3.6%	4.1i	Growth rate of the Agriculture Value Added (tAgGDP) Growth rate of the agriculture value added, in constant US dollars (tAgVA)	0.7%	
						4.1ii	Agriculture contribution to the overall poverty reduction target (Stand-by)	0.7%	
						4.1iii	Reduction rate of poverty headcount ratio, at national poverty line (% of population), dpovN	0.7%	
						4.1iv	Reduction rate of poverty headcount ratio at international poverty line (% of population), dpovI	0.7%	
						4.1v	Reduction rate of the gap between the wholesale price and farmgate price (tfgws)	0.7%	
			PC 4.2	Inclusive PPPs for commodity value chains	3.6%	4.2	Number of priority agricultural commodity value chains for which a PPP is established with strong linkage to smallholder agriculture, (Nc)	3.6%	
			PC 4.3	Youth job in agriculture	3.6%	4.3	Percentage of youth that is engaged in new job opportunities in agriculture value chains, (tYth)	3.6%	
PC 4.4	Women participation in Agri-business	3.6%	4.4	Proportion of rural women that are empowered in agriculture, (tWE)	3.6%				
5	Intra-African Trade in Agriculture Commodities	14.3%	PC 5.1	Intra-African Trade in agriculture commodities and services	7.1%	5.1	Growth rate of the value of trade of agricultural commodities and services within Africa, in constant US dollars (tIAT)	7.1%	
			PC 5.2	Intra-African Trade Policies and institutional conditions	7.1%	5.2i	Trade Facilitation Index (TFI)	3.6%	
						5.2ii	Domestic Food Price Volatility Index (CV)	3.6%	
6	Resilience to Climate Variability	14.3%	PC 6.1	Resilience to climate related risks	7.1%	6.1i	Percentage of farm, pastoral, and fisher households that are resilient to climate and weather related shocks (tRAGHh)	3.6%	
						6.1ii	Share of agriculture land under sustainable land management practices (SSLM)	3.6%	
			PC 6.2	Investment in resilience building	7.1%	6.2	Existence of government budget-lines to respond to spending needs on resilience building initiatives (EI _{RB})	7.1%	
7	Mutual Accountability for Actions and Results	14.3%	PC 7.1	Country capacity for evidence based planning, impl. and M&E	4.8%	7.1	Index of capacity to generate and use agriculture statistical data and information (ASCI)	4.8%	
			PC 7.2	Peer Review and Mutual Accountability	4.8%	7.2	Existence of inclusive institutionalized mechanisms and platforms for mutual accountability and peer review (ECI)	4.8%	
			PC 7.3	Biennial Agriculture Review Process	4.8%	7.3	Country Biennial Report submission (BR)	4.8%	
Total		100%				100%			100%
Number		7				23			43



Technical Notes 1

**Performance Evaluation for achieving goals under Theme 1 :
“COUNTRY COMMITMENT TO CAADP PROCESS”**



PC 1.1 | Country CAADP Process

1.1- CAADP process to be fully completed at the country level: Reach 100% of the completion, CAADPpro, by 2018 .

I-score_{1.1} | Estimating progress on completing CAADP Process

Baseline Yr	2015
Target Yr	2018

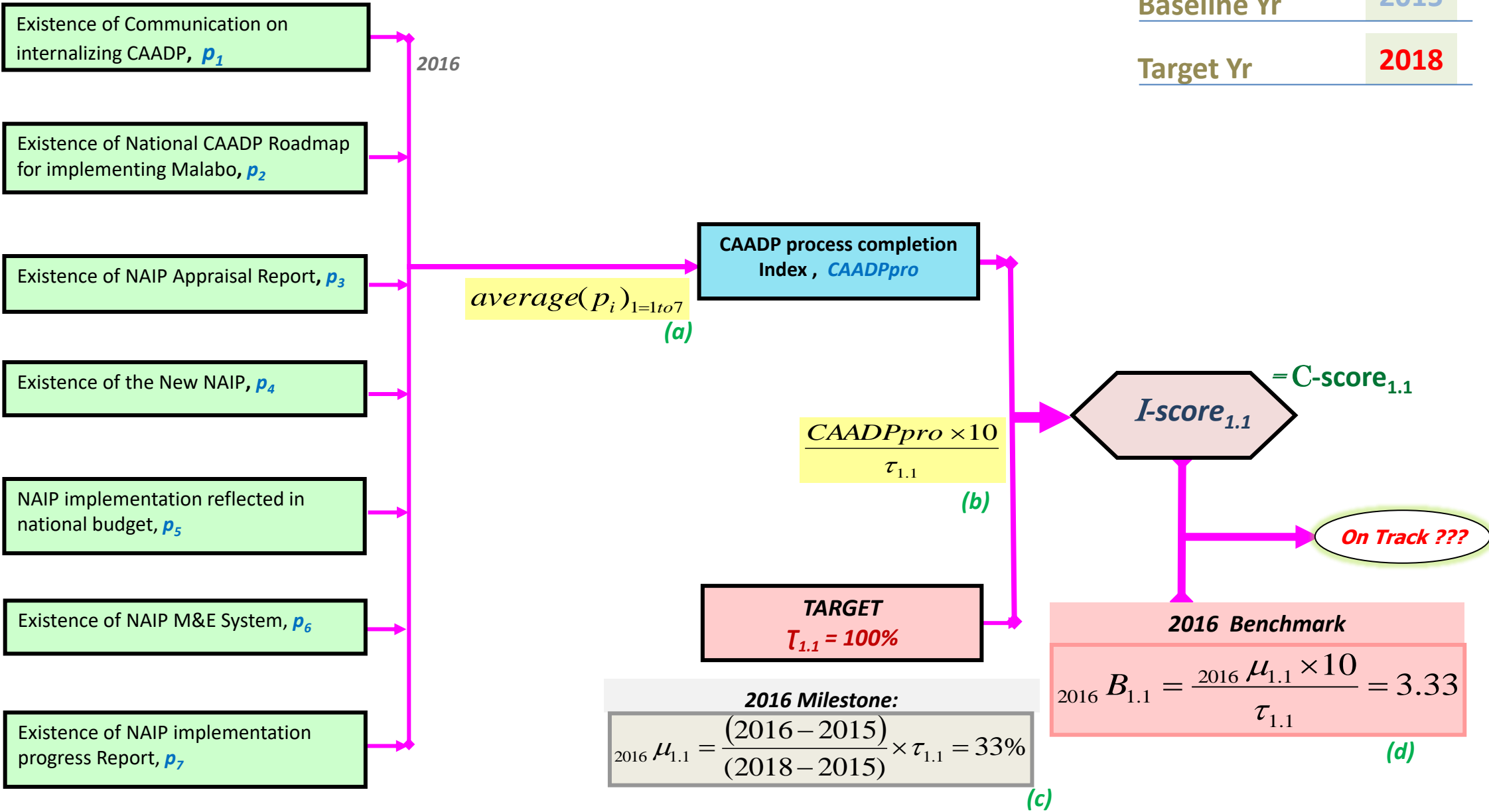

PC 1.2 | CAADP based Cooperation, Partnership & Alliance

1.2- Multi-sectorial **coordination body** and multi-stakeholder body fully established and operational at national level: **Reach 100%** for the Quality of multi-sectorial and multi-stakeholder coordination body, **Qc, by 2018.**

I-score_{1.2} | Estimating progress on establishing multi-sectorial coordination body and multi-stakeholder body

- Existence of the TORs, p_{TOR1}
- Reflection of the key elements, p_{TOR2}
- Representation of stakeholders, p_{TOR3}
- Relevance of membership, p_{TOR4}
- Existence of List of official nominees and affiliation, p_{TOR5}

Existence of quality terms of reference, Qc_1

$av.(p_{TOR(i)})$ (e) $W_1 = 10\%$

- Performance for meetings held, p_{IPM1}
- Level of engagement, p_{IMP2}

Level of implementation of the coordination actions, Qc_2

$(p_{IPM1} + p_{IMP2}) / 2$ (f) $W_2 = 25\%$

- Total number of organizations, N_{org}
- Total number of meetings organized, N_{mO}
- Number of organizations present at each meetings organized, N_{orgi}

Level of participation and inclusiveness, Qc_3

$\sum(N_{orgi}) / (N_{org} \times N_{mO})$ (g) $W_3 = 25\%$

- Total number of recommendations taken during the evaluation period, N_{RT}
- Total number of decisions taken with out of the number of recommendations during the evaluation period, N_{DT}
- Number of decisions implemented, N_{DI}

Level of commitment to decisions, Qc_4

(N_{DI} / N_{RT}) (h) $W_4 = 20\%$

- Total expected senior attendance per meeting, T_{SA}
- Total number of meetings organized, N_{mO}
- Observed senior attendance at each meetings organized, Q_{SAi}

Level of representation, Qc_5

$\sum(Q_{SAi}) / (N_{mO} \times T_{SA})$ (i) $W_5 = 20\%$

2016

$\sum_{i=1}^5 (Qc_i \times w_i)$ (j)

Existence of, and Quality of multi-sectorial and multi-stakeholder coordination body, Qc

$\frac{Qc \times 10}{\tau_{1.2}}$ (k)

TARGET $\tau_{1.2} = 100\%$

2016 Milestone: ${}_{2016} \mu_{1.2} = \frac{(2016 - 2015)}{(2018 - 2015)} \times \tau_{1.2} = 33\%$ (l)

Baseline Yr	2015
Target Yr	2018

I-score_{1.2} = C-score_{1.2}

On Track ???

2016 Benchmark ${}_{2016} B_{1.2} = \frac{{}_{2016} \mu_{1.2} \times 10}{\tau_{1.2}} = 3.33$ (m)

PC 1.3 | CAADP based Policy & Institutional Review/ Setting/ Support

- 1.3- Evidence-based policies and institutions that support planning and implementation are established and implemented by the country to deliver on Malabo: Reach 100% for the Evidence-based policies, supportive institutions and corresponding human resources, EIP, by 2018.
-

I-score_{1.3} | Estimating progress on establishing evidence based policies and institutions

Baseline Yr	2015
Target Yr	2018

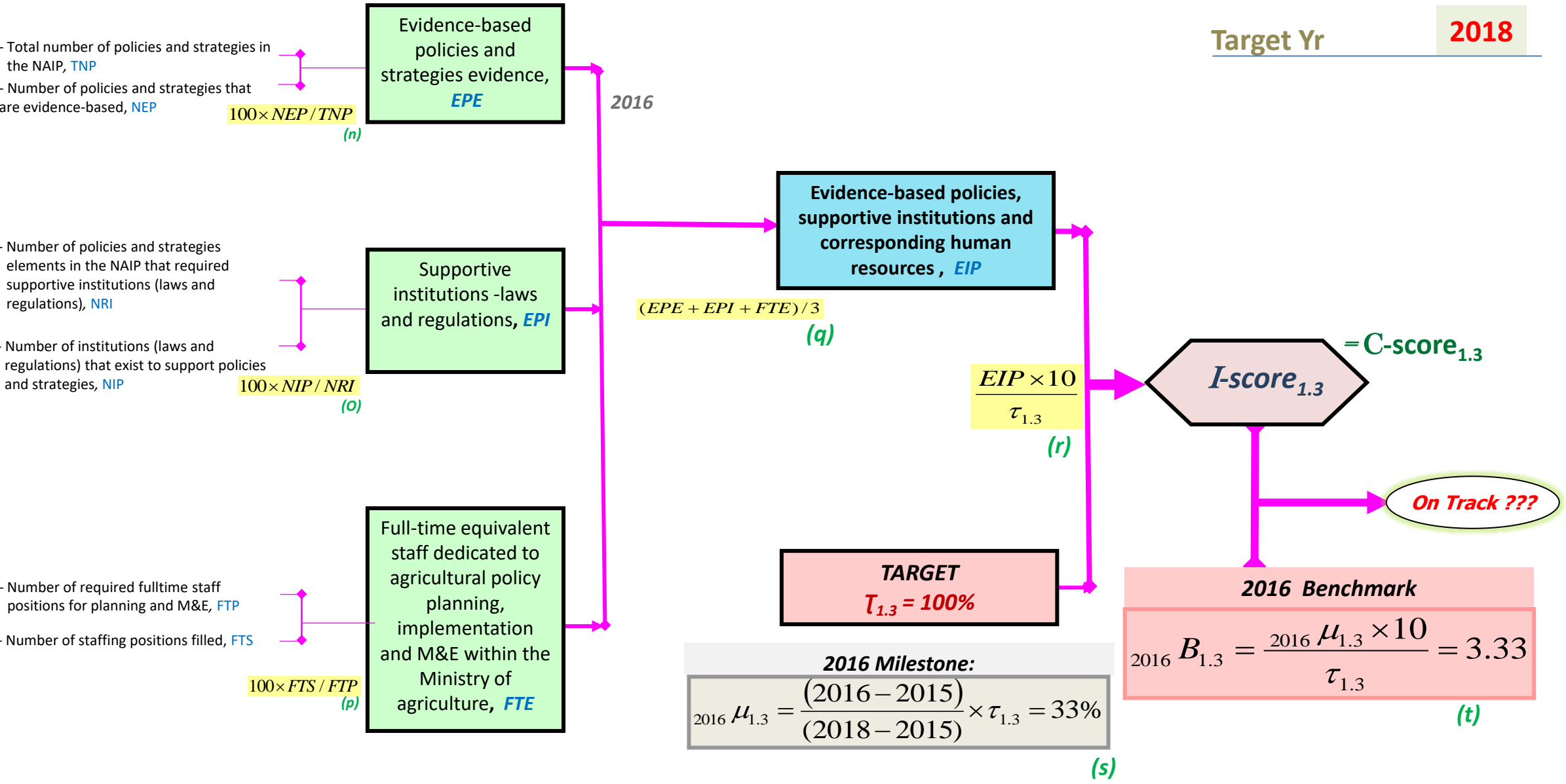

T-score₁ | Overall progress for Theme 1: "COUNTRY COMMITMENT TO CAADP PROCESS"

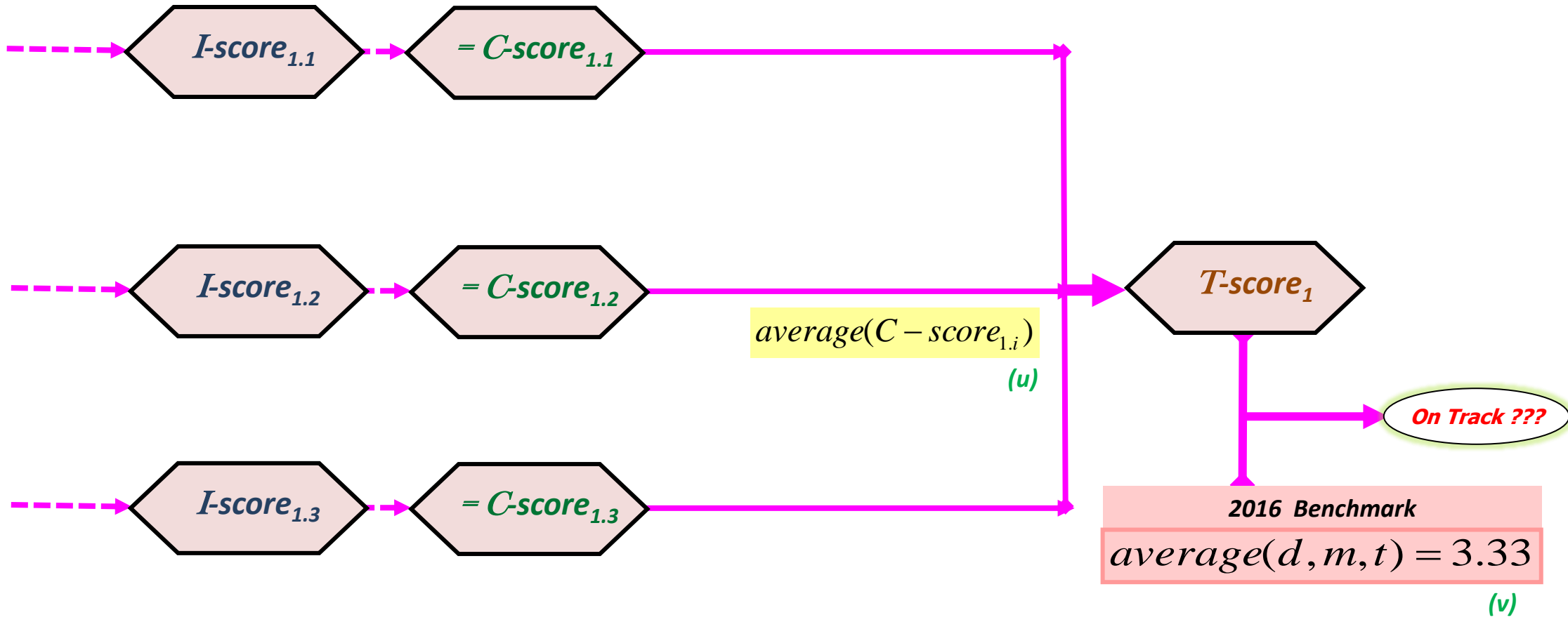



Technical Notes 2

**Performance Evaluation for achieving goals under Theme 2 :
“INVESTMENT FINANCE IN AGRICULTURE”**



PC 2.1 | Public Expenditures to Agriculture

2.1i- Increase public expenditures to agriculture as part of national expenditures, to at least 10% , from 2015 to 2025.

2.1ii- Ensure adequate intensity of agricultural spending by keeping annual public agriculture expenditure as % of agriculture value added to no less than (or at a minimum of) 19% from 2015 to 2025.

2.1iii- Ensure that Official Development Assistance (ODA) committed to implement the NAIPs is fully disbursed to countries. The target is to have 100% ODA disbursement annually from 2015 to 2025.

I-score_{2.1i} | Estimating progress on public expenditures in agriculture

Baseline Yr	2015
Target Yr	2025

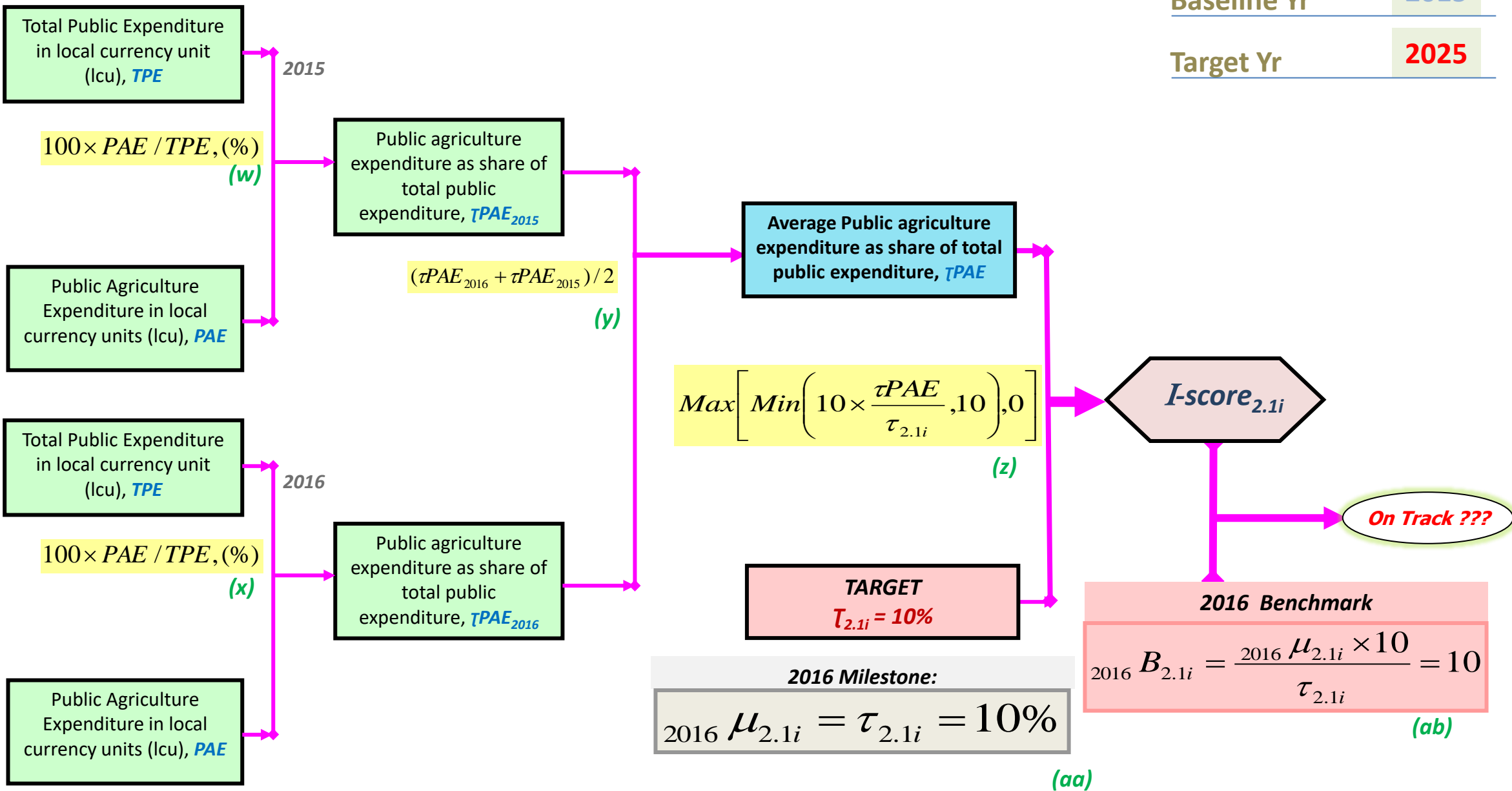

I-score_{2.1ii} | Estimating progress on intensity of agricultural spending

Baseline Yr	2015
Target Yr	2025

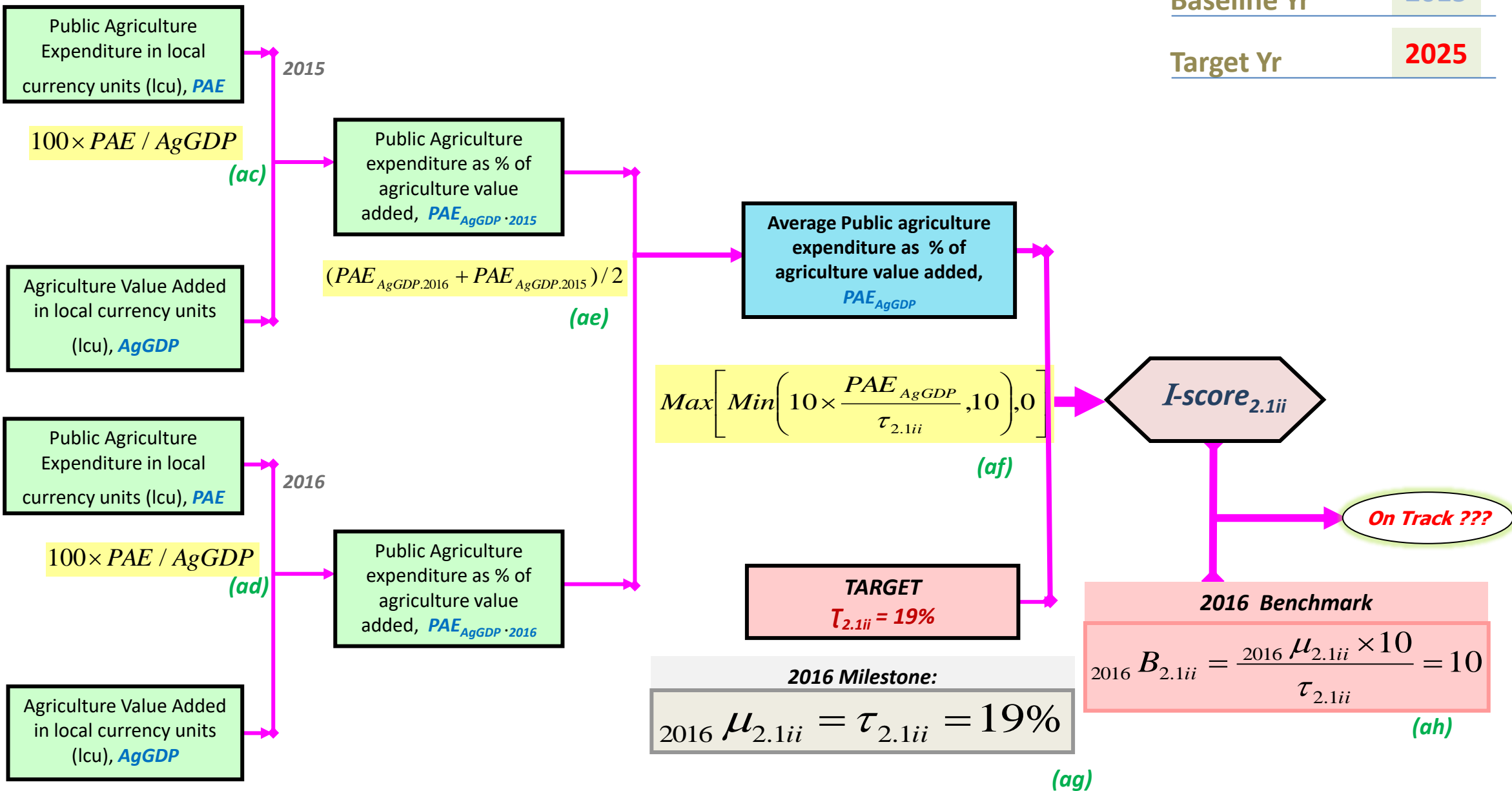

I-score_{2.1iii} | Estimating progress on ODA disbursement to agriculture

Baseline Yr	2015
Target Yr	2025

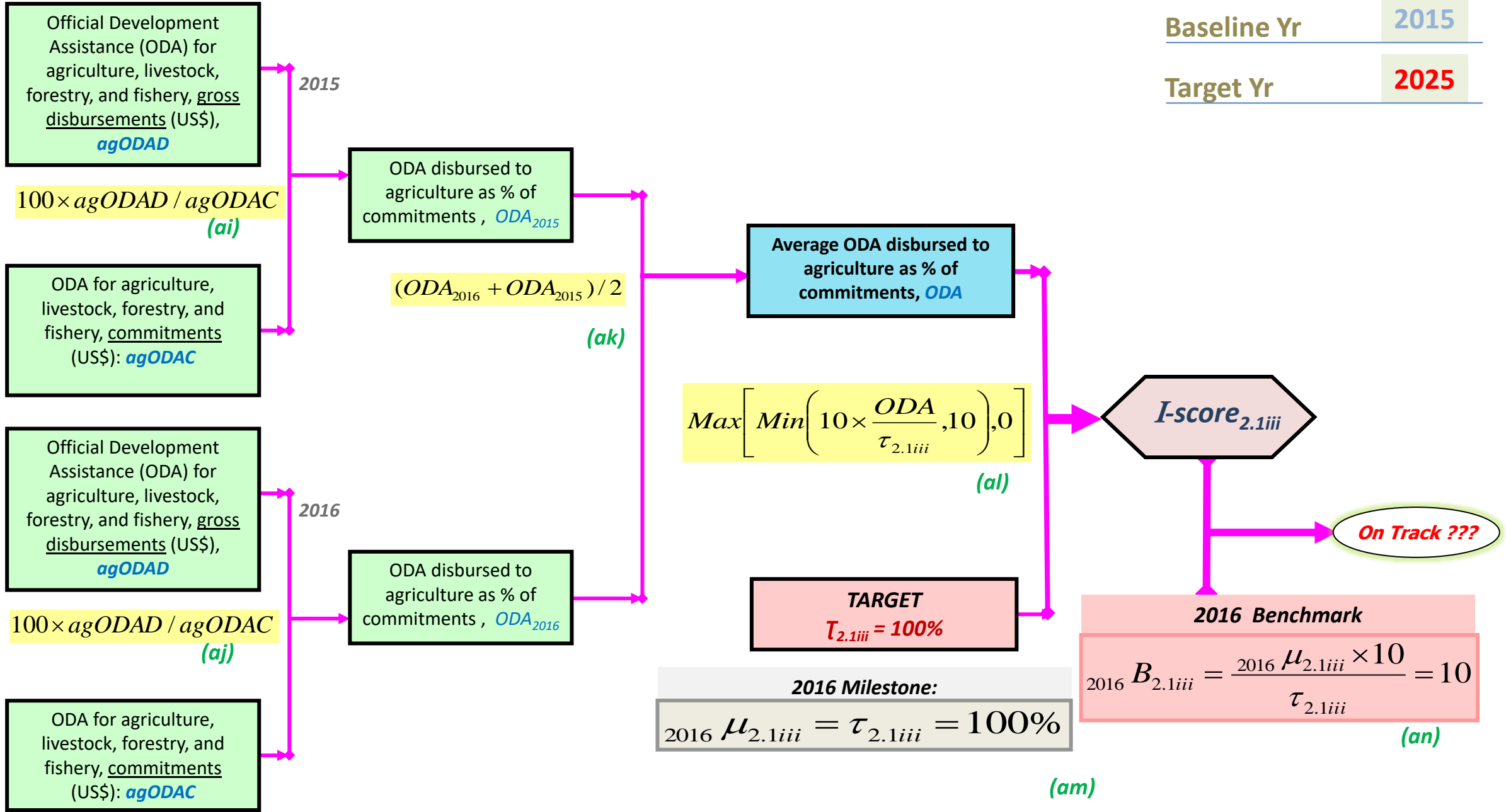

C-score_{2.1} | Combined progress on Public Expenditures to Agriculture

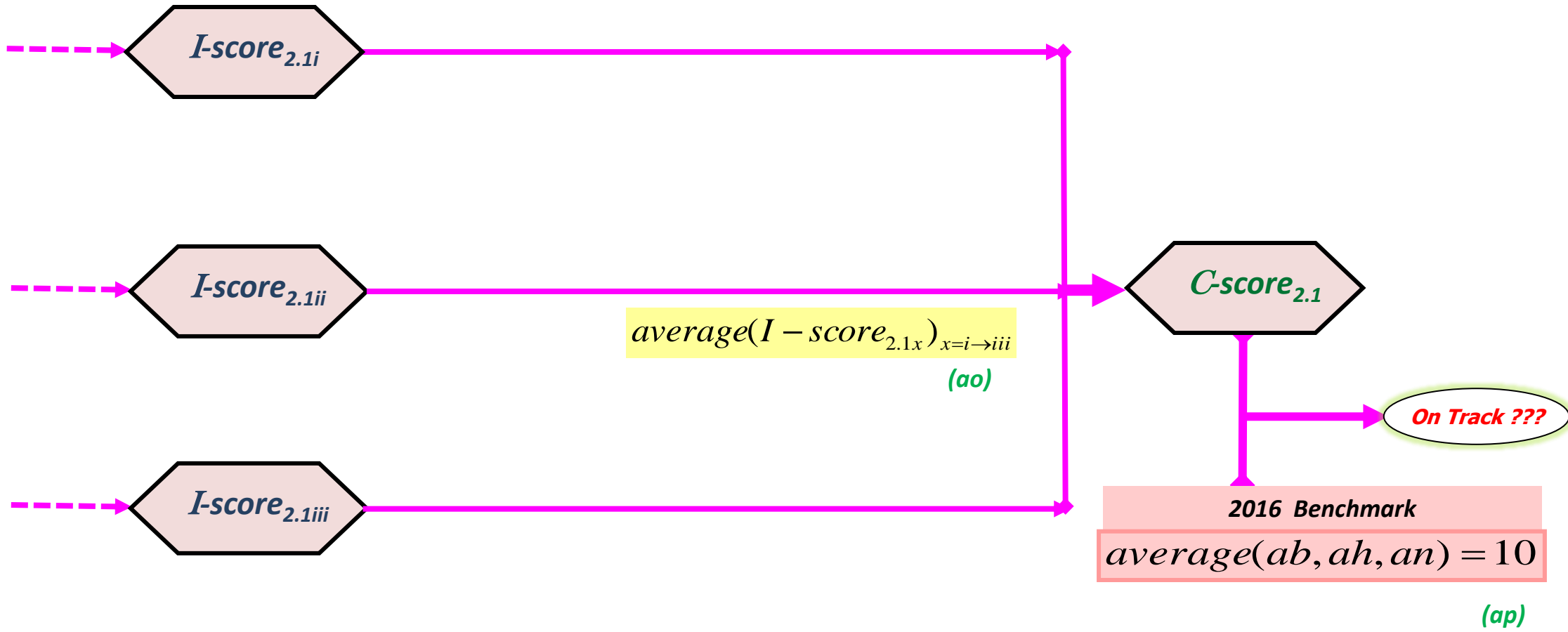

PC 2.2 | Domestic Private Sector Investment in Agriculture

2.2- Ensure that government investment leverage at least **X times**, domestic private investment in agriculture sector by **2025**.



I-score_{2.2} | Estimating progress on domestic private investment in agriculture

Baseline Yr	2015
Target Yr	2025

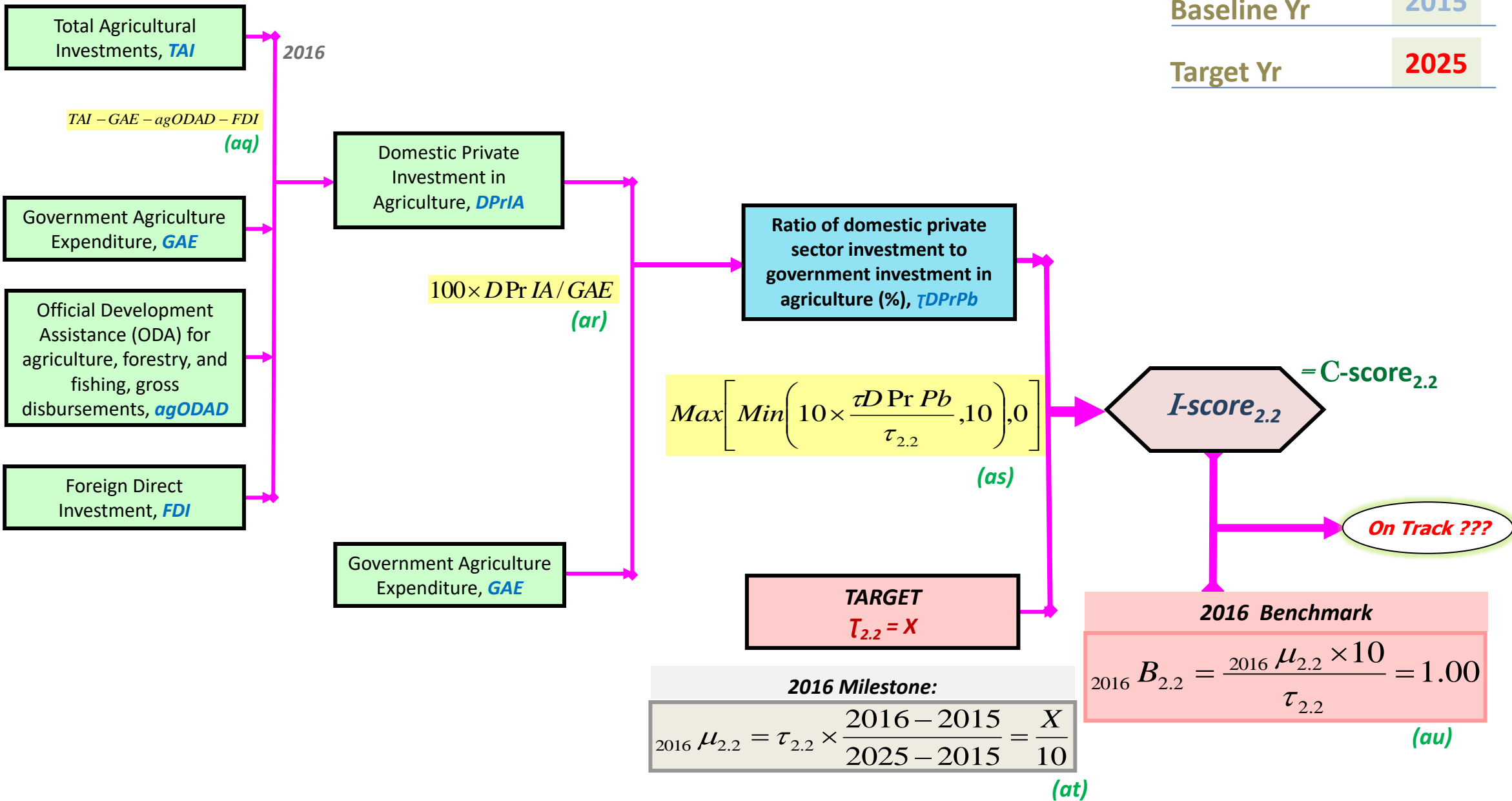

PC 2.3 | Foreign Private Sector Investment in Agriculture

2.3- Ensure that government investment leverage at least **Y times**, **foreign private direct investment** in agriculture sector **by 2025**.

I-score_{2.3} | Estimating progress on foreign private investment in agriculture

Baseline Yr	2015
Target Yr	2025

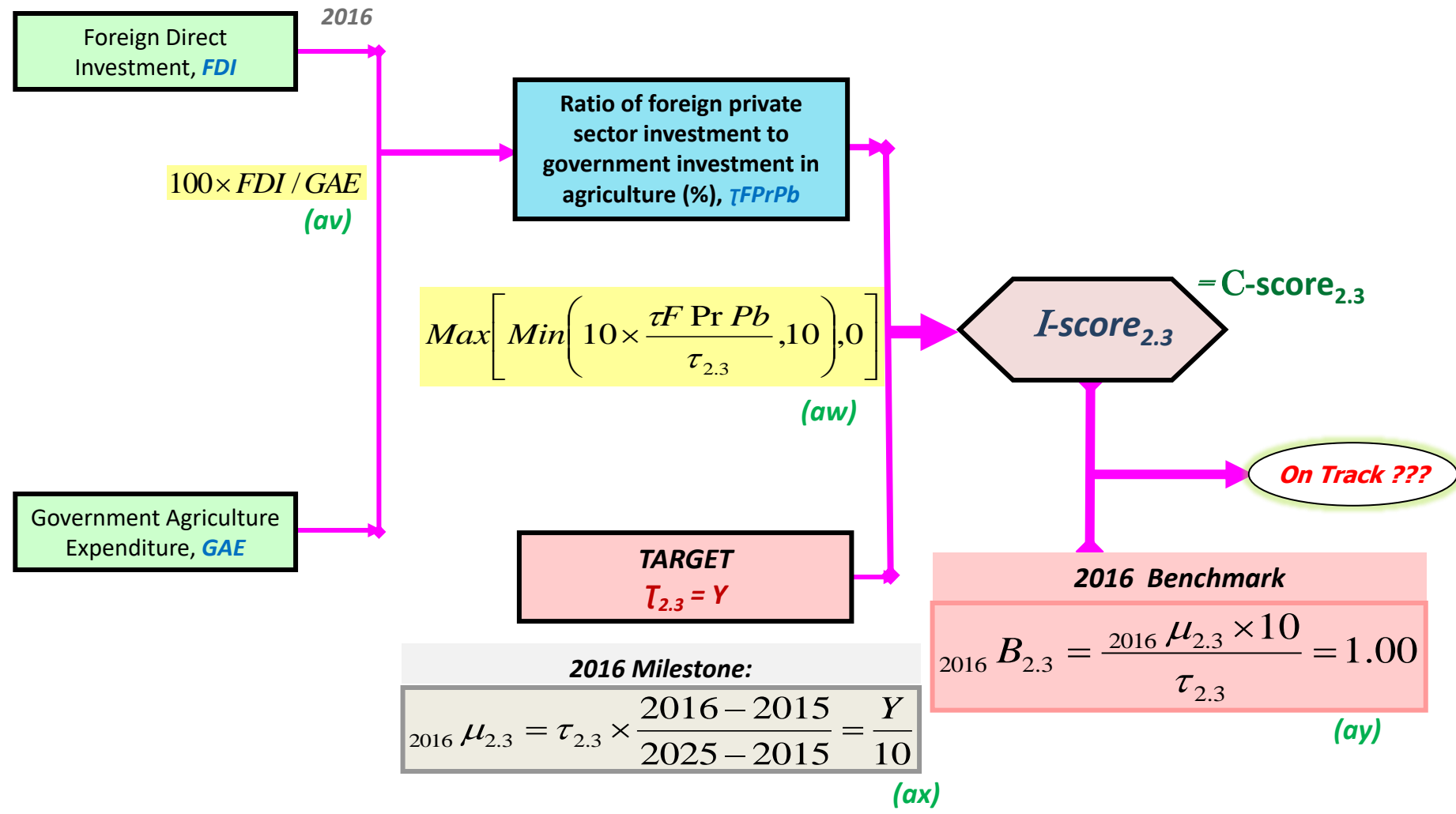

PC 2.4 | Market Access

2.4- Ensure that 100% of men and women engaged in agriculture have access to financial services to be able to transact agriculture business, by 2018.



I-score_{2.4} | Estimating progress on market access

Baseline Yr	2015
Target Yr	2018

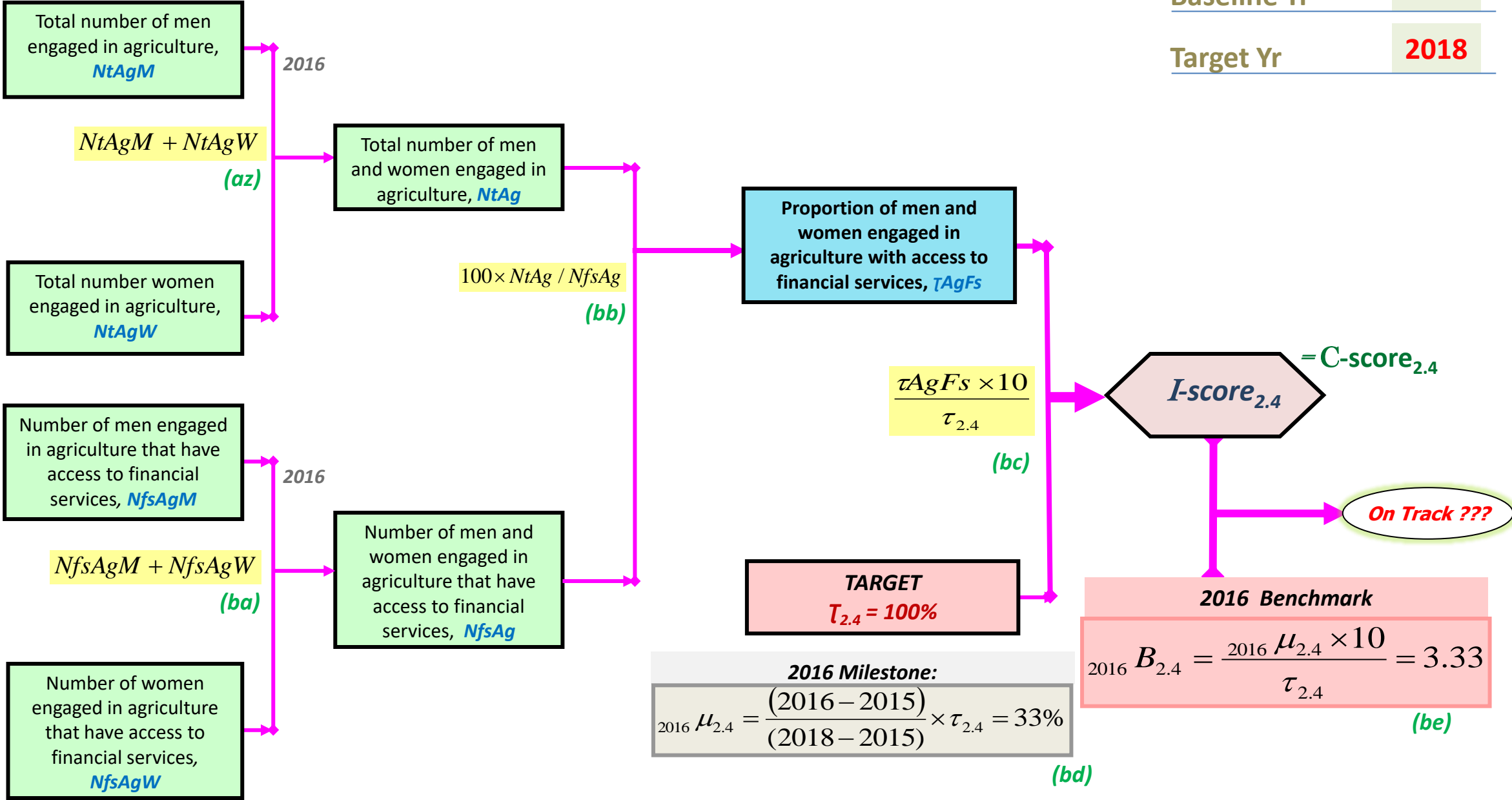

T-score₂ | Overall progress for Theme 2: "INVESTMENT FINANCE IN AGRICULTURE"

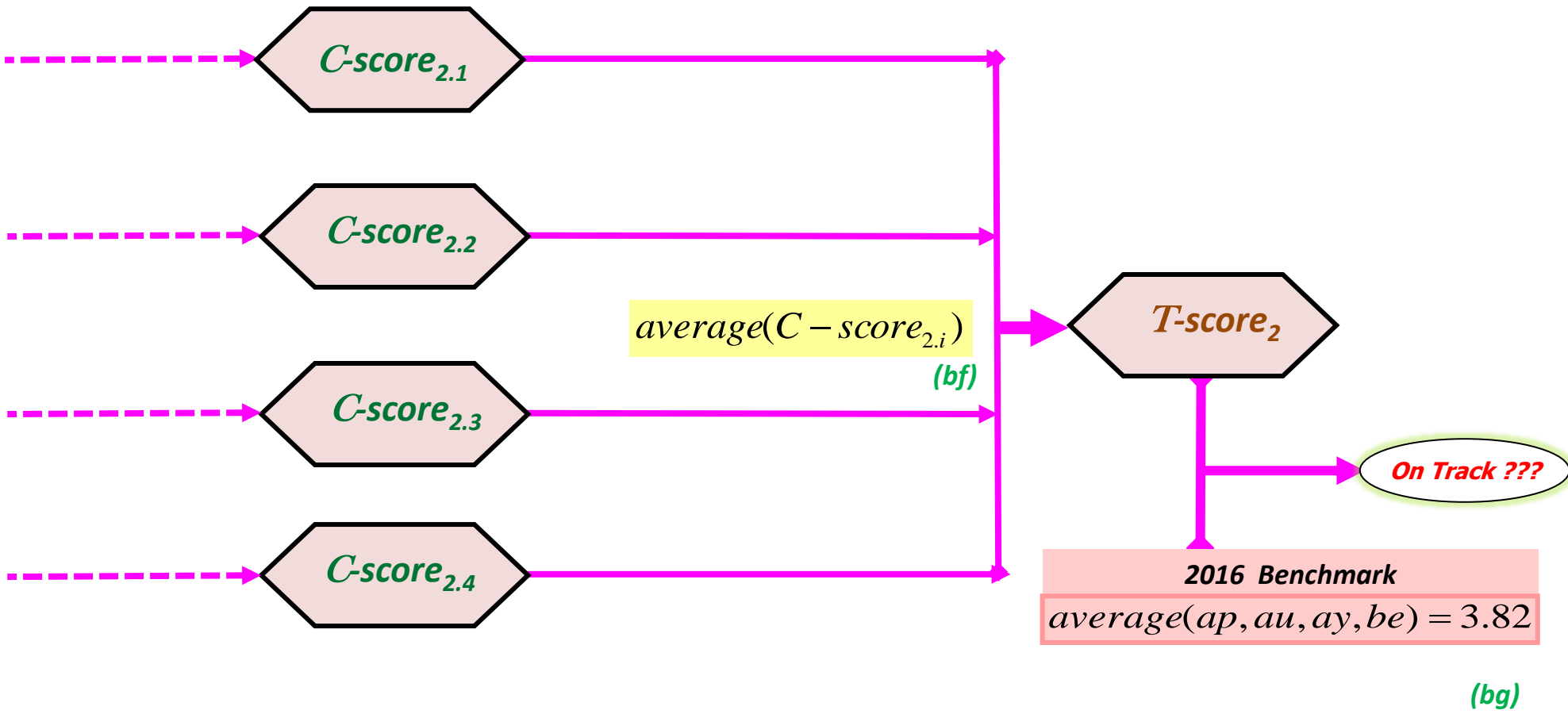



Technical Notes 3

**Performance Evaluation for achieving goals under Theme 3 :
“ENDING HUNGER”**



PC 3.1 | Access to Agriculture inputs and technologies

3.1i- Ensure minimum **use of fertilizer** for African agriculture development at level of consumption of at **least 50 kilograms/ha** of arable land, from **2015 to 2025**.

3.1ii- Increase the **size of irrigated areas** (as per its value observed in the **year 2000**), by **100%** by the year **2025**.

3.1iii- **Double (100% increase)** the **current levels of quality agricultural inputs for crops (seed), livestock (breed), and fisheries (fingerlings)** by **2025**, from **2015**.

PC 3.1 | Access to Agriculture inputs and technologies

3.1iv- All farmers have access to quality agricultural advisory services that provide locally relevant knowledge, information and other services by 2018.

3.1v- Increase the level of Investments in Agricultural Research and Development to at least 1% of the Agricultural GDP, from 2015 to 2025.

3.1vi- Ensure that 100% of farmers and agribusiness interested in agriculture have rights to access the required land, by 2018.

I-score_{3.1i} | Estimating progress on fertilizer use (organic and/or inorganic)

Baseline Yr	2015
Target Yr	2025

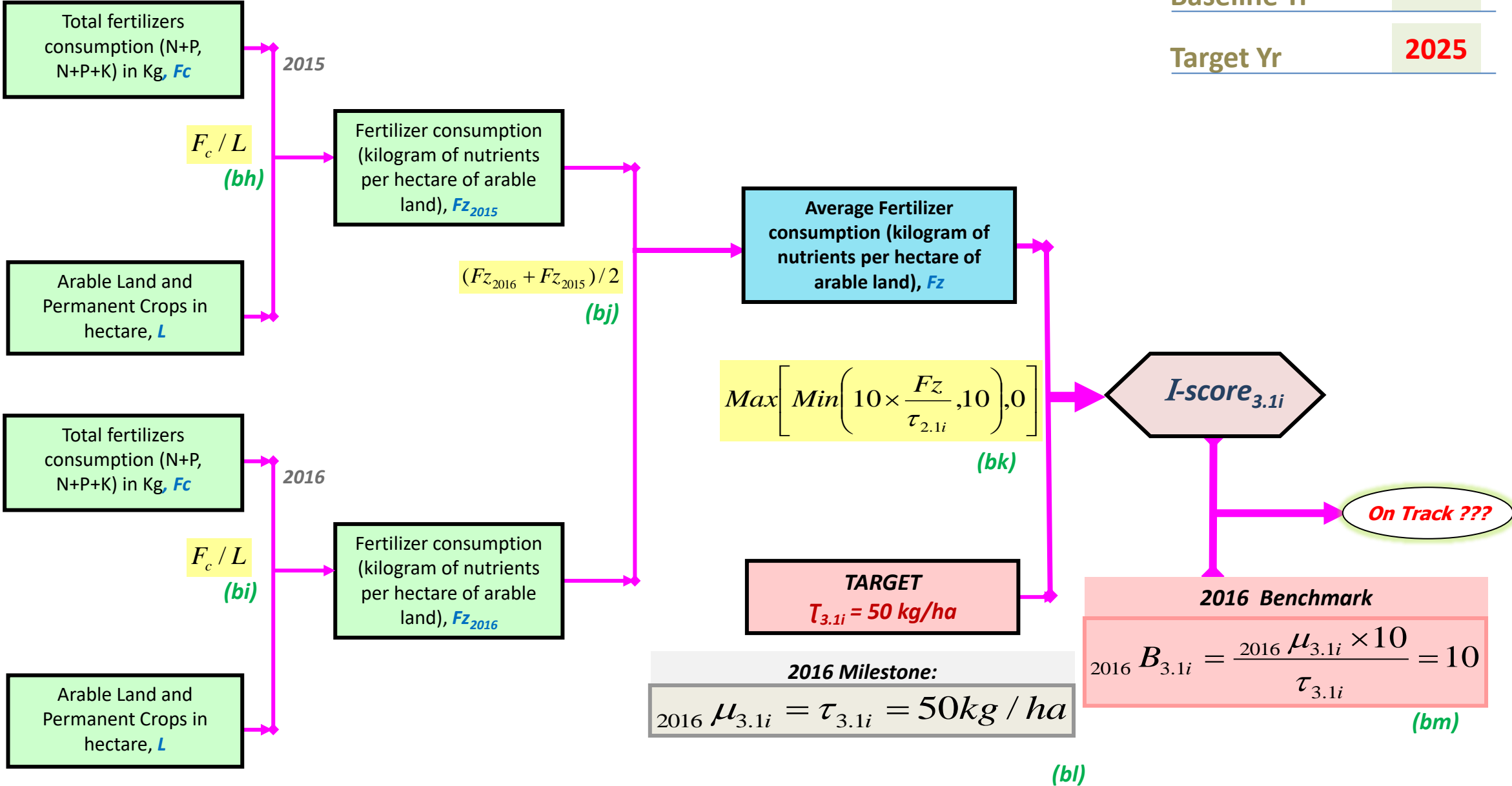

I-score_{3.1ii} | Estimating progress on the size of irrigated areas

Baseline Yr	2000
Target Yr	2025

Size of Irrigated areas ,
*IA*₂₀₁₆

$$100 \times (IA_{2016} - IA_{2000}) / IA_{2000}$$

(bn)

Size of Irrigated areas ,
*IA*₂₀₀₀

Growth rate of the size of irrigated area (in %),
R_iA

$$\begin{cases} \max \left(\left[\frac{R_i A}{25\%} \times 2.5 \right]; 0 \right) & R_i A \leq 25\% \\ \left(2.5 + \frac{R_i A - 25\%}{50\% - 25\%} (5.0 - 2.5) \right) & 25\% \leq R_i A \leq 50\% \\ \min \left(\left[5.0 + \frac{R_i A - 50\%}{100\% - 50\%} (10 - 5.0) \right]; 10 \right) & 50\% \leq R_i A \end{cases}$$

(bo)

The milestone 2005 of 25% and the milestone 2015 of 50% in the same commitment, are to be considered in the scoring method. It is called the multi-targets situation in the Easy-Theory. (***)

*I-score*_{3.1ii}

On Track ???

TARGET
*T*_{3.1ii} = 100%

2016 Benchmark

$${}_{2016} B_{3.1ii} = \frac{{}_{2016} \mu_{3.1ii} \times 10}{\tau_{3.1ii}} = 5.50$$

(bq)

2016 Milestone:

$${}_{2016} \mu_{3.1ii} = {}_{2015} \mu_{3.1ii} + \frac{(2016 - 2015)}{(2025 - 2015)} \times (\tau_{3.1ii} - {}_{2015} \mu_{3.1ii}) = 55\%$$

(***) ${}_{2005} \mu_{3.1ii} = 25\%$ ${}_{2015} \mu_{3.1ii} = 50\%$ (bp)

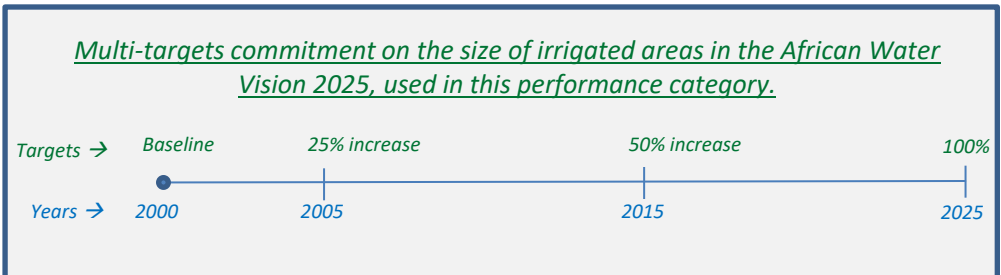

I-score_{3.1iii} | Estimating progress on quality agricultural inputs for crops (seed), livestock (breed), and fisheries (fingerlings)

Baseline Yr 2015
Target Yr 2025

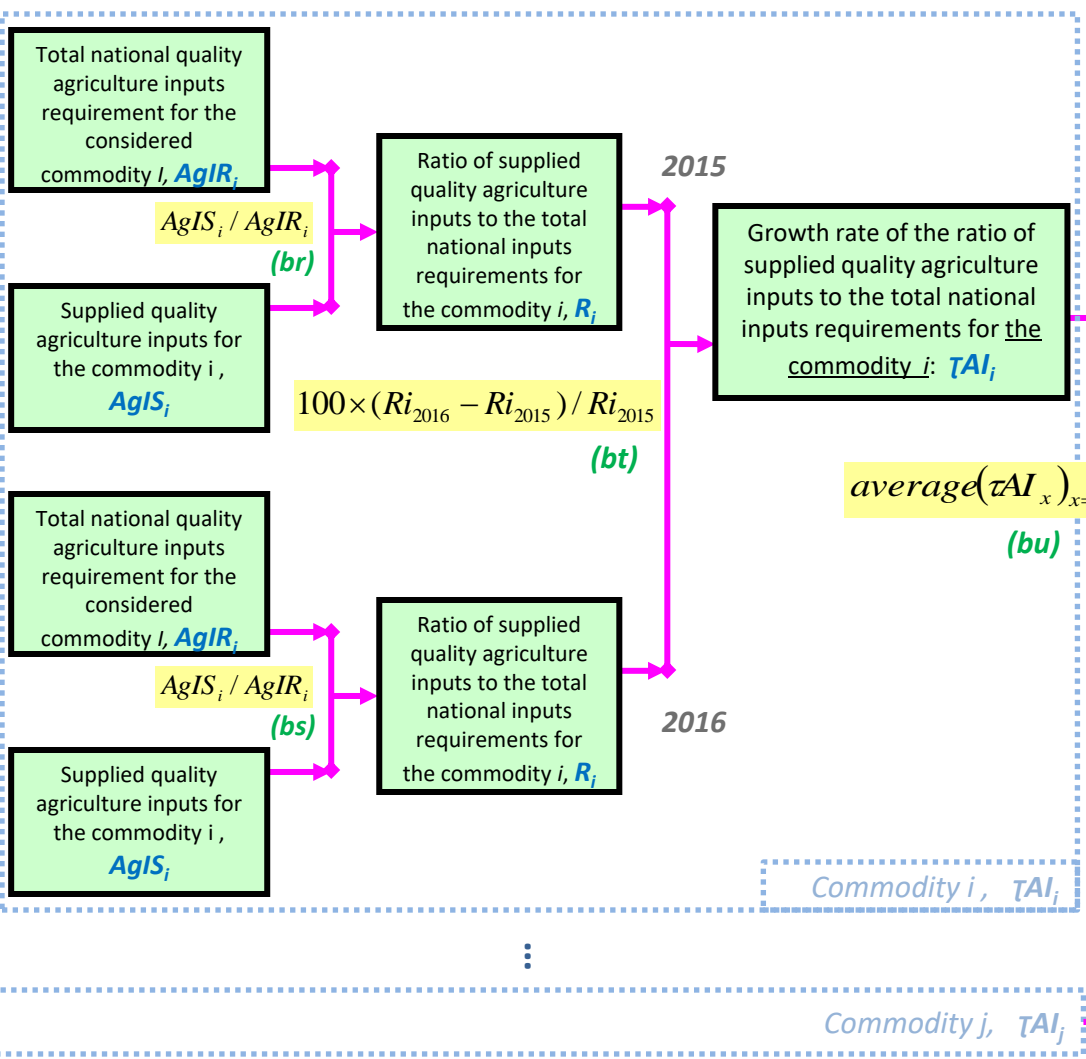

Average Growth rate of the ratio of supplied quality agriculture inputs to the total national inputs requirements, τAI

$$Max \left[Min \left(10 \times \frac{\tau AI}{\tau_{3.1iii}}, 10 \right), 0 \right]$$

(bv)

TARGET
 $\tau_{3.1iii} = 100\%$

2016 Milestone:

$${}_{2016} \mu_{3.1iii} = \frac{(2016 - 2015)}{(2025 - 2015)} \times \tau_{3.1iii} = 10\%$$

(bw)

I-score_{3.1iii}

On Track ???

2016 Benchmark

$${}_{2016} B_{3.1iii} = \frac{{}_{2016} \mu_{3.1iii} \times 10}{\tau_{3.1iii}} = 1.00$$

(bx)

I-score_{3.1iv} | Estimating progress on access to quality agricultural advisory services

Baseline Yr	2015
Target Yr	2018

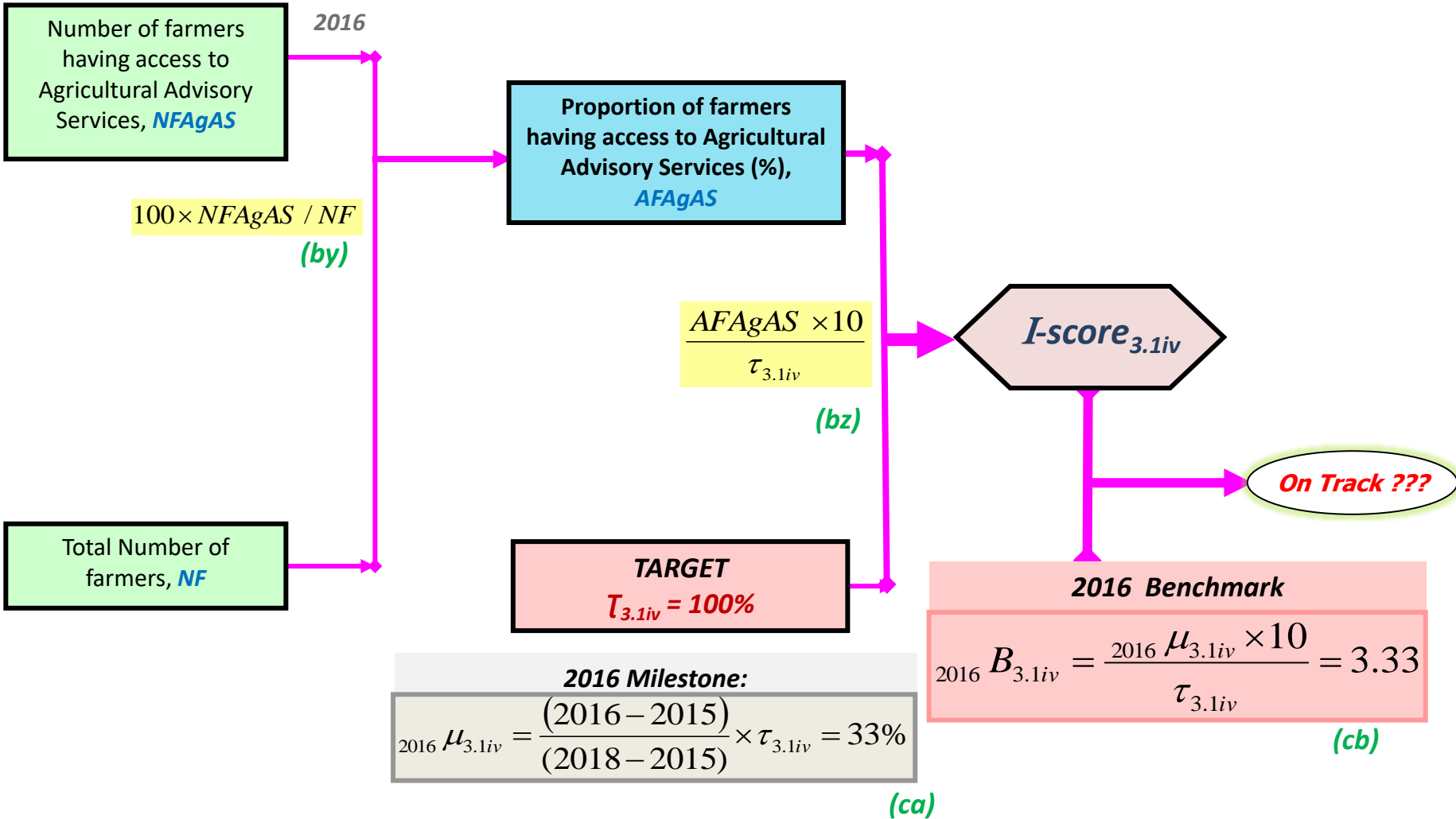

I-score_{3.1v} | Estimating progress on investment in agriculture research and development

Baseline Yr	2015
Target Yr	2025

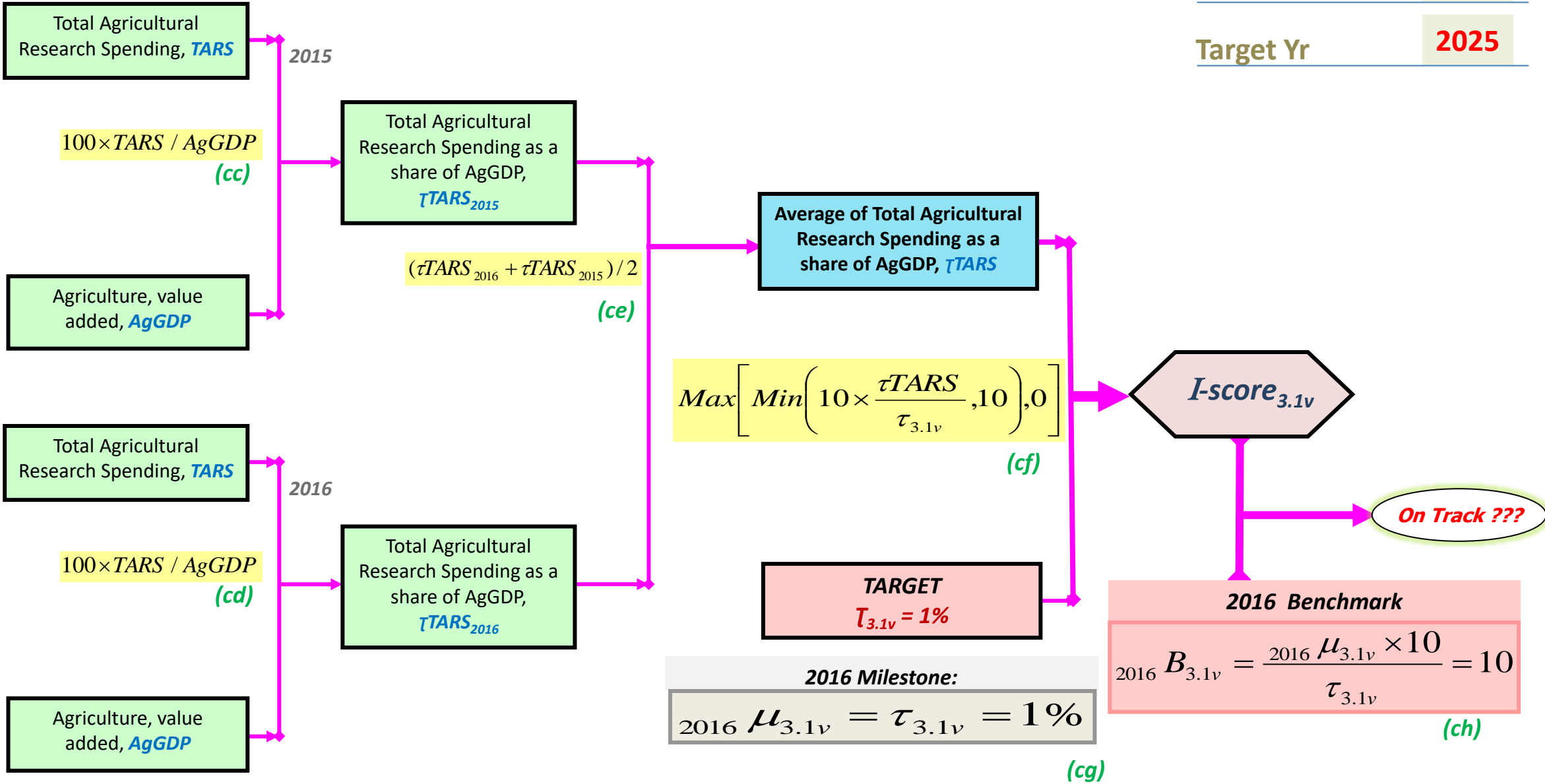

I-score_{3.1vi} | Estimating progress on access to land

Baseline Yr	2015
Target Yr	2018

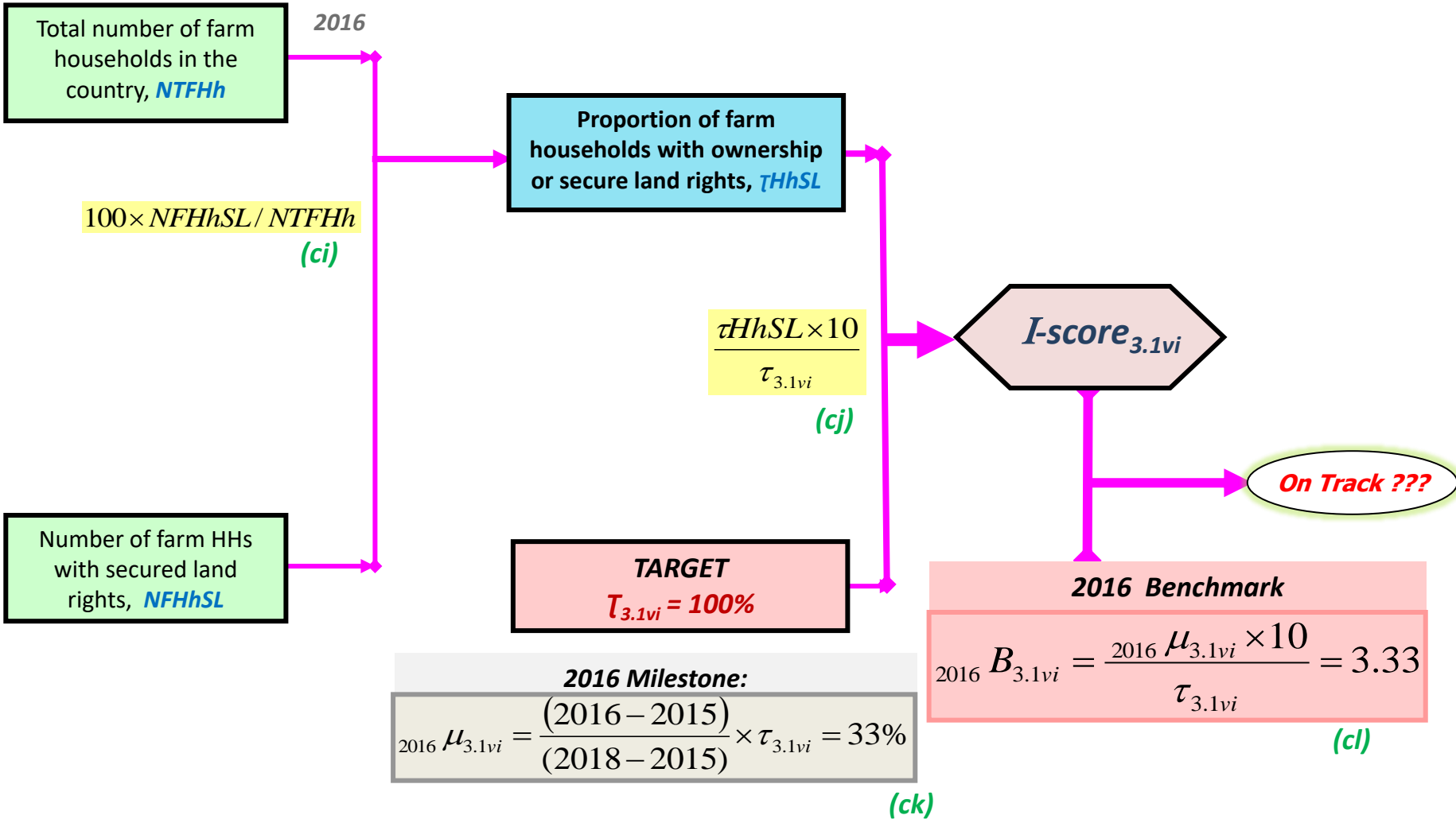

C-score_{3.1} | Combined progress on Access to Agriculture inputs and technologies

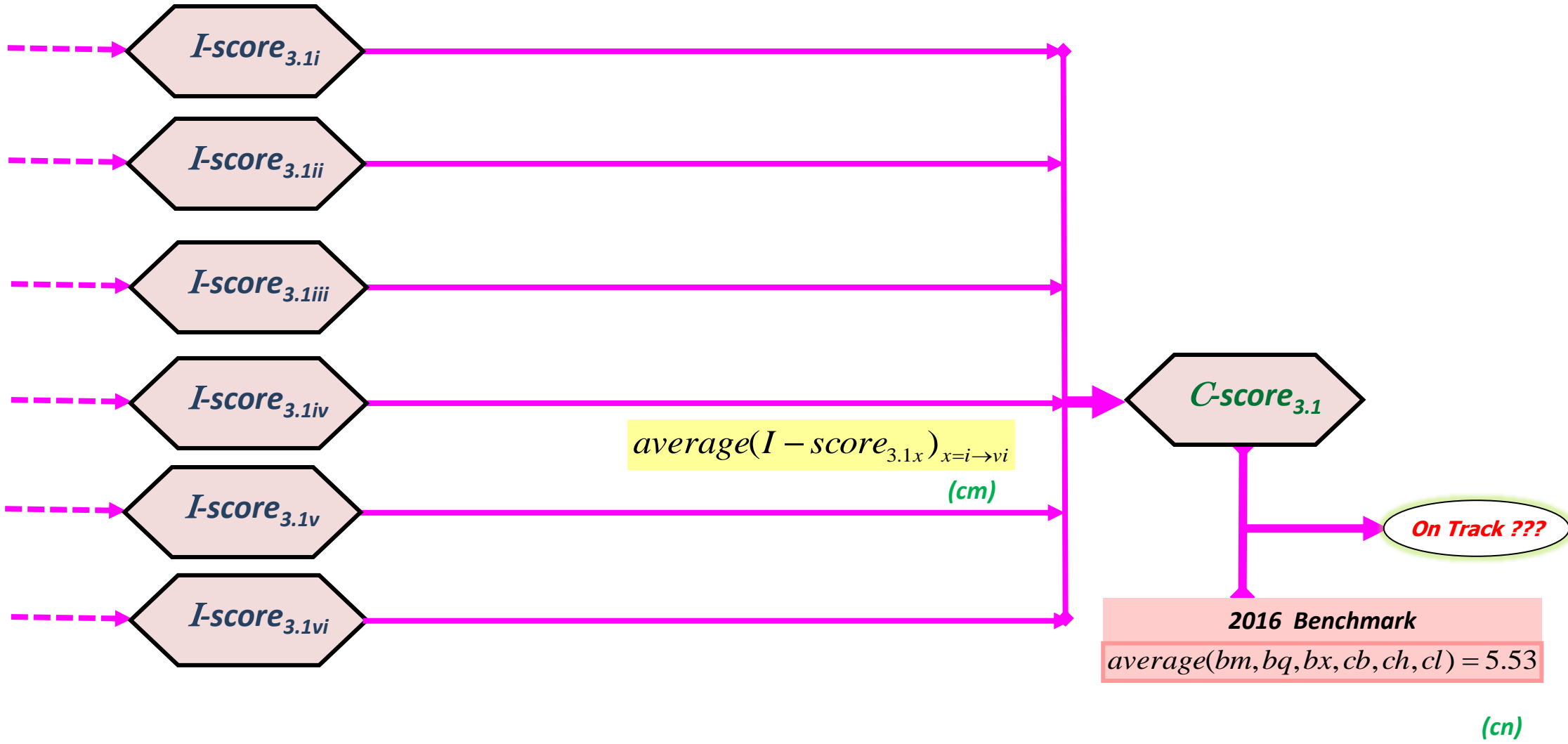

PC 3.2 | Agricultural Productivity

3.2i- Double (100% increase) the current agricultural labor productivity levels by the from 2015 to 2025.

3.2ii- Double (increase by 100%) the current agricultural land productivity levels, by 2025 from 2015.

3.2iii- Double (100% increase) the current agricultural yield levels, by 2025 from 2015.

I-score_{3.2i} | Estimating progress on labor productivity

Baseline Yr	2015
Target Yr	2025

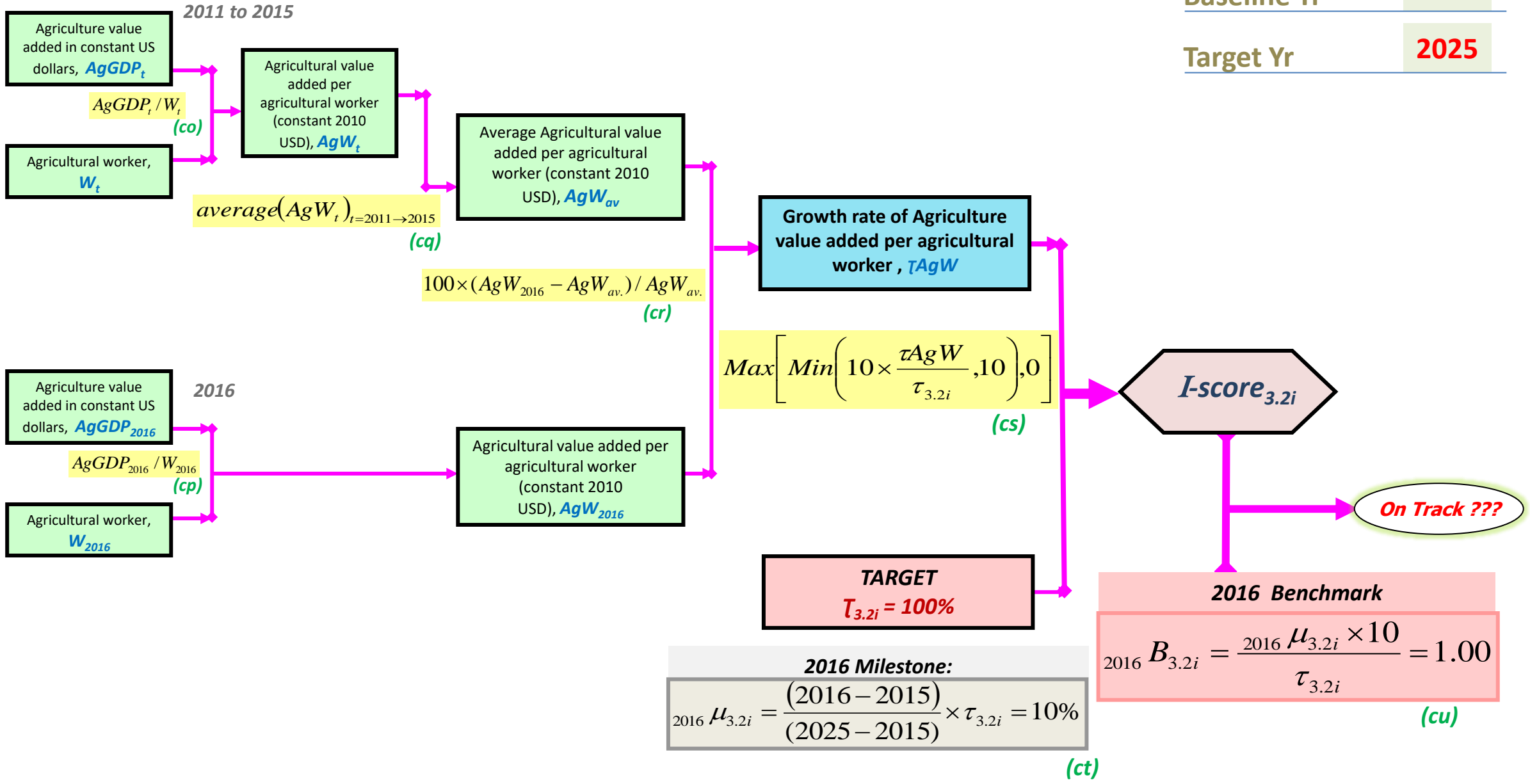

I-score_{3.2ii} | Estimating progress on land productivity

Baseline Yr	2015
Target Yr	2025

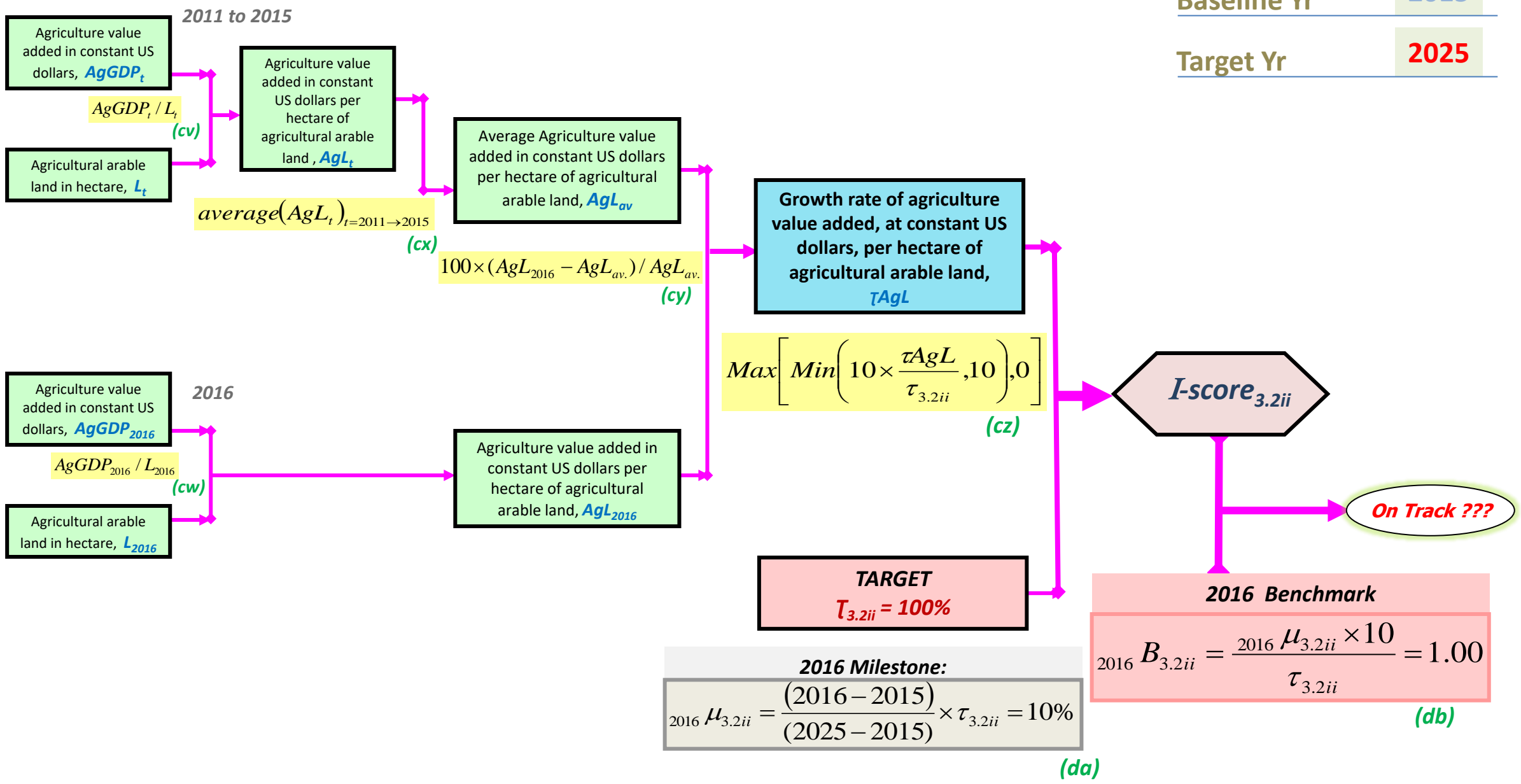

I-score_{3.2iii} | Estimating progress on agricultural yield

Baseline Yr	2015
Target Yr	2025

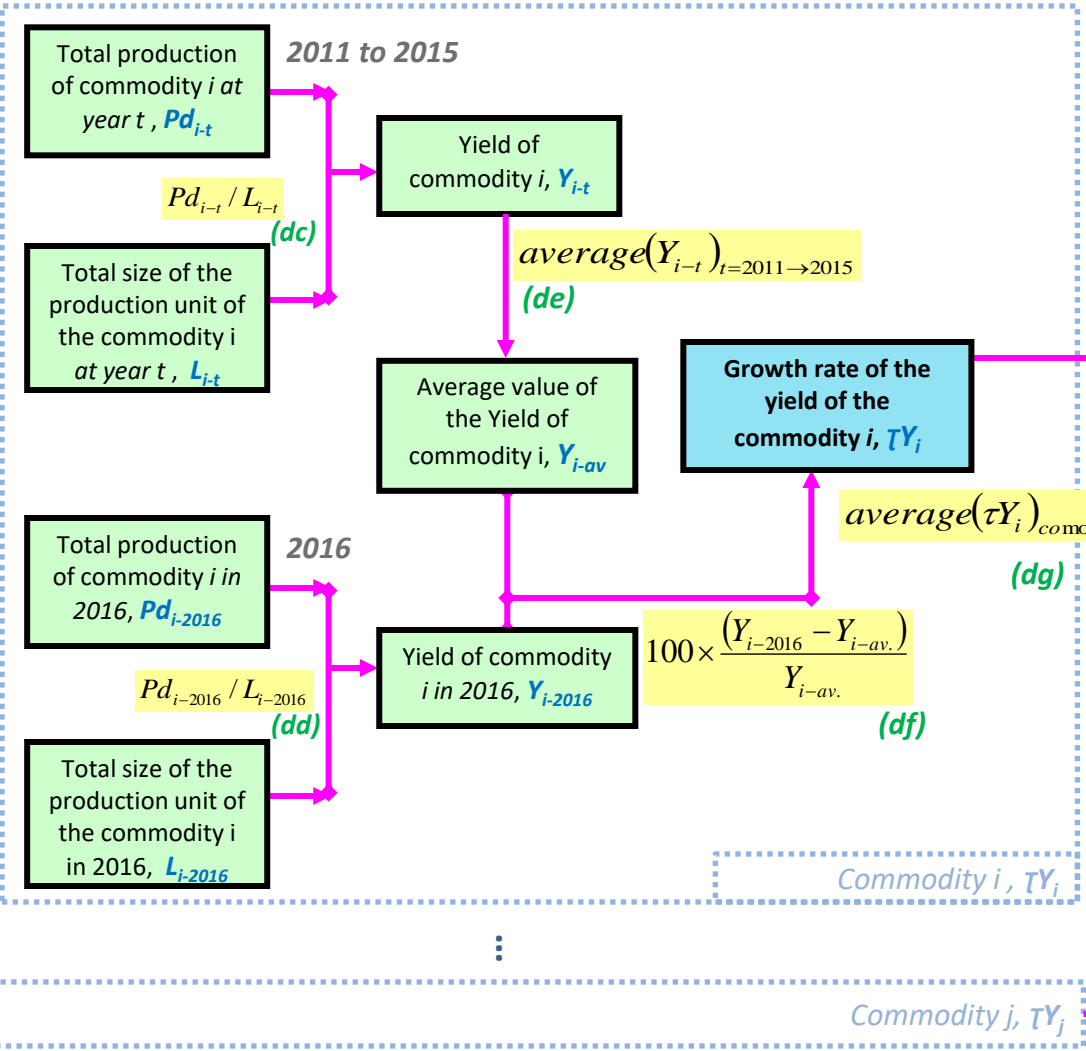

Average of observed growth rates of agricultural yields for all the commodities, τY

$$Max \left[Min \left(10 \times \frac{\tau Y}{\tau_{3.2iii}}, 10 \right), 0 \right]$$

(dh)

TARGET
 $\tau_{3.2iii} = 100\%$

2016 Milestone:

$${}_{2016} \mu_{3.2iii} = \frac{(2016 - 2015)}{(2025 - 2015)} \times \tau_{3.2iii} = 10\%$$

(di)

I-score_{3.2iii}

On Track ???

2016 Benchmark

$${}_{2016} B_{3.2iii} = \frac{{}_{2016} \mu_{3.2iii} \times 10}{\tau_{3.2iii}} = 1.00$$

(dj)

For at least the 5 priority commodities of the country and the 11 African Union priority commodities that include: -Rice, -Maize, -Legumes, -Cotton, -Oil palm, -Beef, -Dairy, -Poultry and fisheries, -Cassava, -Sorghum and -Millet.

C-score_{3.2} | Combined progress on Agriculture Productivity

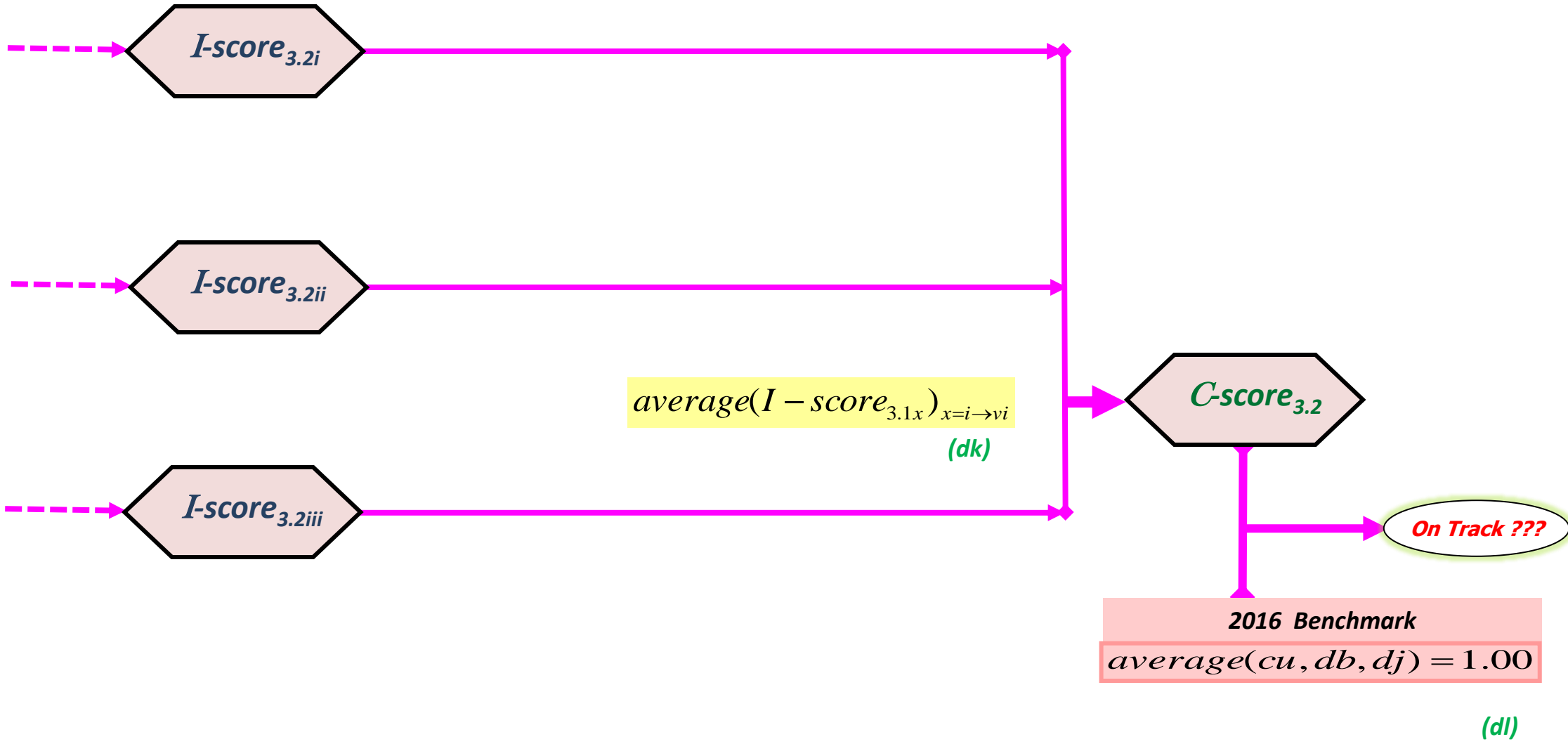

PC 3.3 | Post-Harvest Loss

3.3- Halve (decrease by 50%) the current levels of Post-Harvest Losses (PHL), by the 2025 from 2015.

I-score_{3.3} | Estimating progress on Post-Harvest Loss

Baseline Yr	2015
Target Yr	2025

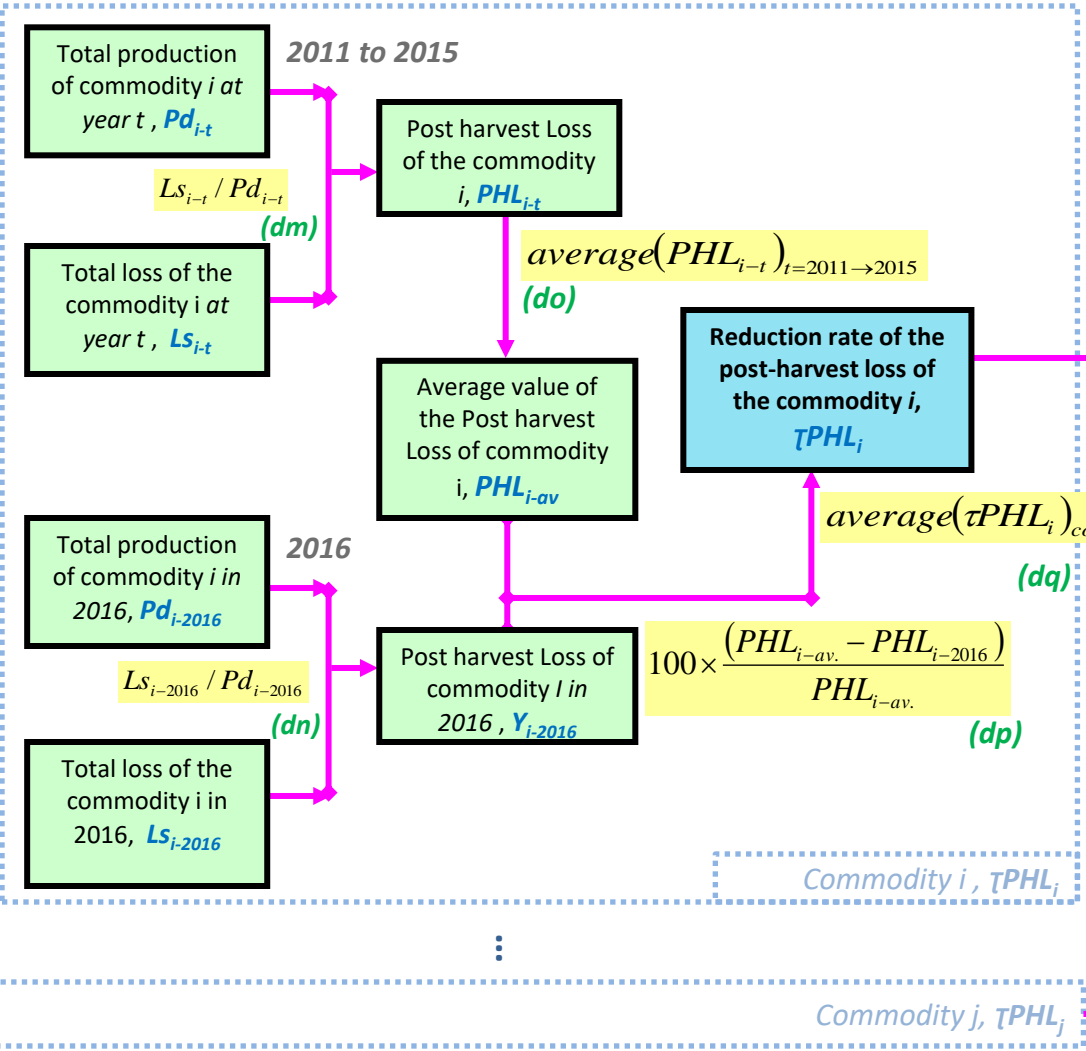

Average of observed reduction rates of post-harvest loss for all the commodities, τPHL

$$\text{Max} \left[\text{Min} \left(10 \times \frac{\tau PHL}{\tau_{3.3}}, 10 \right), 0 \right]$$

(dr)

TARGET $\tau_{3.3} = 50\%$

2016 Milestone:

$${}_{2016} \mu_{3.3} = \frac{(2016 - 2015)}{(2025 - 2015)} \times \tau_{3.3} = 5\%$$

(ds)

= C-score_{3.3}

I-score_{3.3}

On Track ???

2016 Benchmark

$${}_{2016} B_{3.3} = \frac{{}_{2016} \mu_{3.3} \times 10}{\tau_{3.3}} = 1.00$$

(dt)

For at least the 5 priority commodities of the country and the 11 African Union priority commodities that include: -Rice, -Maize, -Legumes, -Cotton, -Oil palm, -Beef, -Dairy, -Poultry and fisheries, -Cassava, -Sorghum and -Millet.

PC 3.4 | Social Protection

3.4- Commit within national budgets, budget lines that amount to 100% of the total resource requirements for coverage of the vulnerable social groups, from 2015 to 2025, for use to support social protection initiatives, and to address any eventual disasters and emergencies with food and nutrition security implications.

I-score_{3,4} | Estimating progress on Social Protection

Baseline Yr	2015
Target Yr	2025

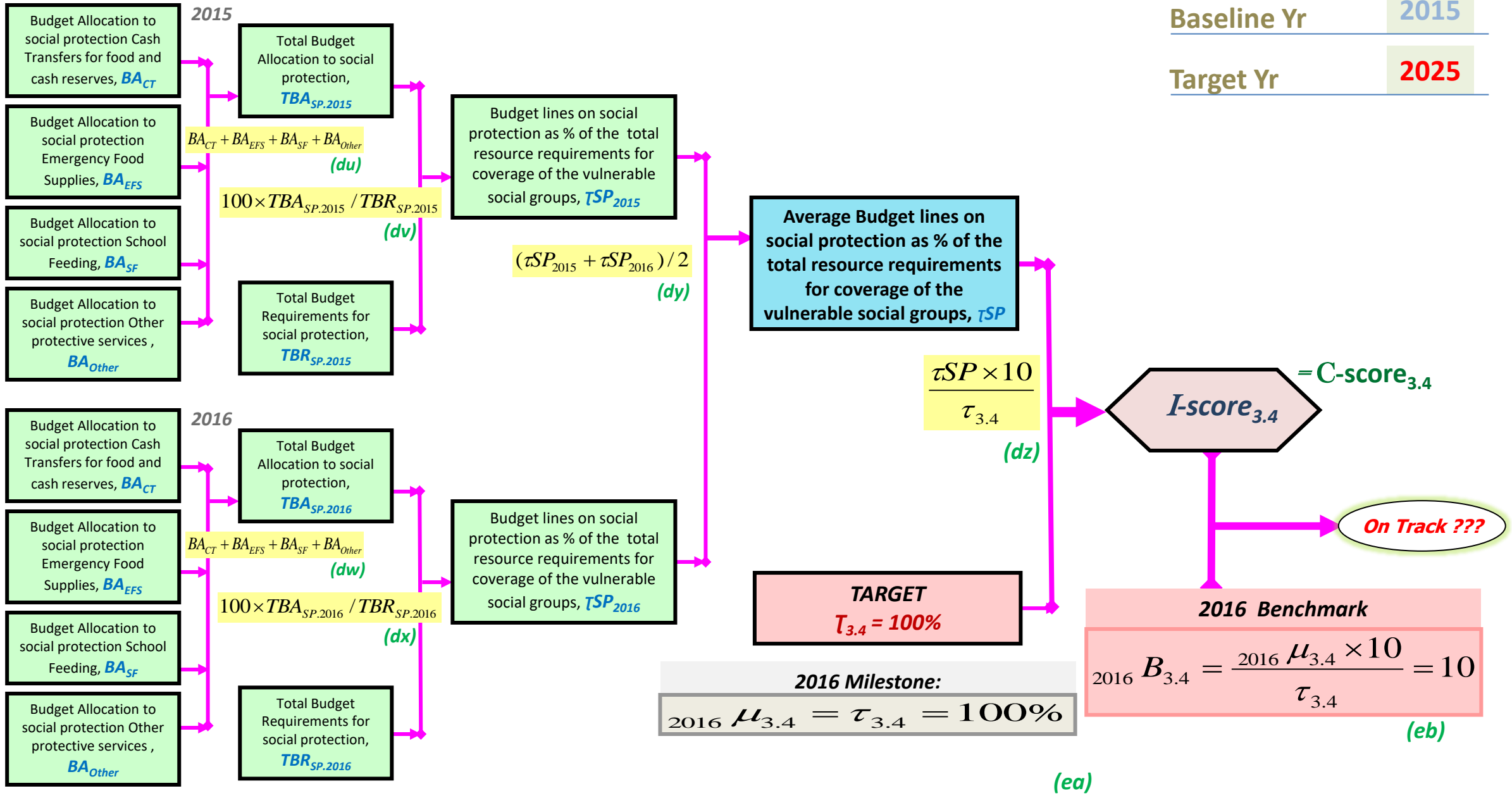

PC 3.5 | Food security and Nutrition

3.5i- Bring down **child stunting to 10% or less, by 2025.**

3.5ii- Bring down **underweight to 5% or less, by 2025.**

3.5iii- Bring down **wasting to 5% or less, by 2025.**



PC 3.5 | Food security and Nutrition

3.5iv- Bring down **undernourishment to 5% or less, by 2025.**

3.5v- **Increase the proportion of women at reproductive age that attain the minimum dietary diversity by 50%, by 2025.**

3.5vi- **Reach at least 50% of children 6-23 months that have the minimum acceptable diet by 2025.**

I-score_{3.5i} | Estimating progress on prevalence of stunting

Baseline Yr	2015
Target Yr	2025

2015
Prevalence of stunting (% of children under 5 years old), St_0

2016
Prevalence of stunting (% of children under 5 years old), St

$$\begin{cases} \left[\frac{(St_0 - St)}{(St_0 - \tau_{3.5i})} \times 10 \right]_{St_0 > \tau_{3.5i}} \\ [10]_{St_0 < \tau_{3.5i}} \end{cases}$$

(ec)

TARGET
 $\tau_{3.5i} = 10\%$

2016 Milestone:

$${}_{2016} \mu_{3.5i} = St_0 - \frac{(2016 - 2015)}{(2025 - 2015)} \times (St_0 - \tau_{3.5i})$$

(ed)

I-score_{3.5i}

On Track ???

2016 Benchmark

$${}_{2016} B_{3.5i} = \frac{St_0 - {}_{2016} \mu_{3.5i}}{St_0 - \tau_{3.5i}} \times 10 = 1.00$$

(ee)

... with $St_0 > \tau_{3.5i}$

This is a relative milestone which is specific to each country as it depends on where the country is coming from: the 2015 baseline value ...

I-score_{3.5ii} | Estimating progress on prevalence of underweight

Baseline Yr	2015
Target Yr	2025

2015
Prevalence of underweight (% of children under 5 years old), Uw_0

2016
Prevalence of underweight (% of children under 5 years old), Uw

$$\begin{cases} \left[\frac{(Uw_0 - Uw)}{(Uw_0 - \tau_{3.5ii})} \times 10 \right]_{Uw_0 > \tau_{3.5ii}} \\ [10]_{Uw_0 \leq \tau_{3.5ii}} \end{cases}$$

(ef)

TARGET
 $\tau_{3.5ii} = 5\%$

2016 Milestone:

$${}_{2016} \mu_{3.5ii} = Uw_0 - \frac{(2016 - 2015)}{(2025 - 2015)} \times (Uw_0 - \tau_{3.5ii})$$

This is a relative milestone which is specific to each country as it depends on where the country is coming from: the 2015 baseline value ... (eg)

I-score_{3.5ii}

On Track ???

2016 Benchmark

$${}_{2016} B_{3.5ii} = \frac{Uw_0 - {}_{2016} \mu_{3.5ii}}{Uw_0 - \tau_{3.5ii}} \times 10 = 1.00$$

(eh)

... with $Uw_0 > \tau_{3.5ii}$

I-score_{3.5iii} | Estimating progress on prevalence of wasting

Baseline Yr	2015
Target Yr	2025

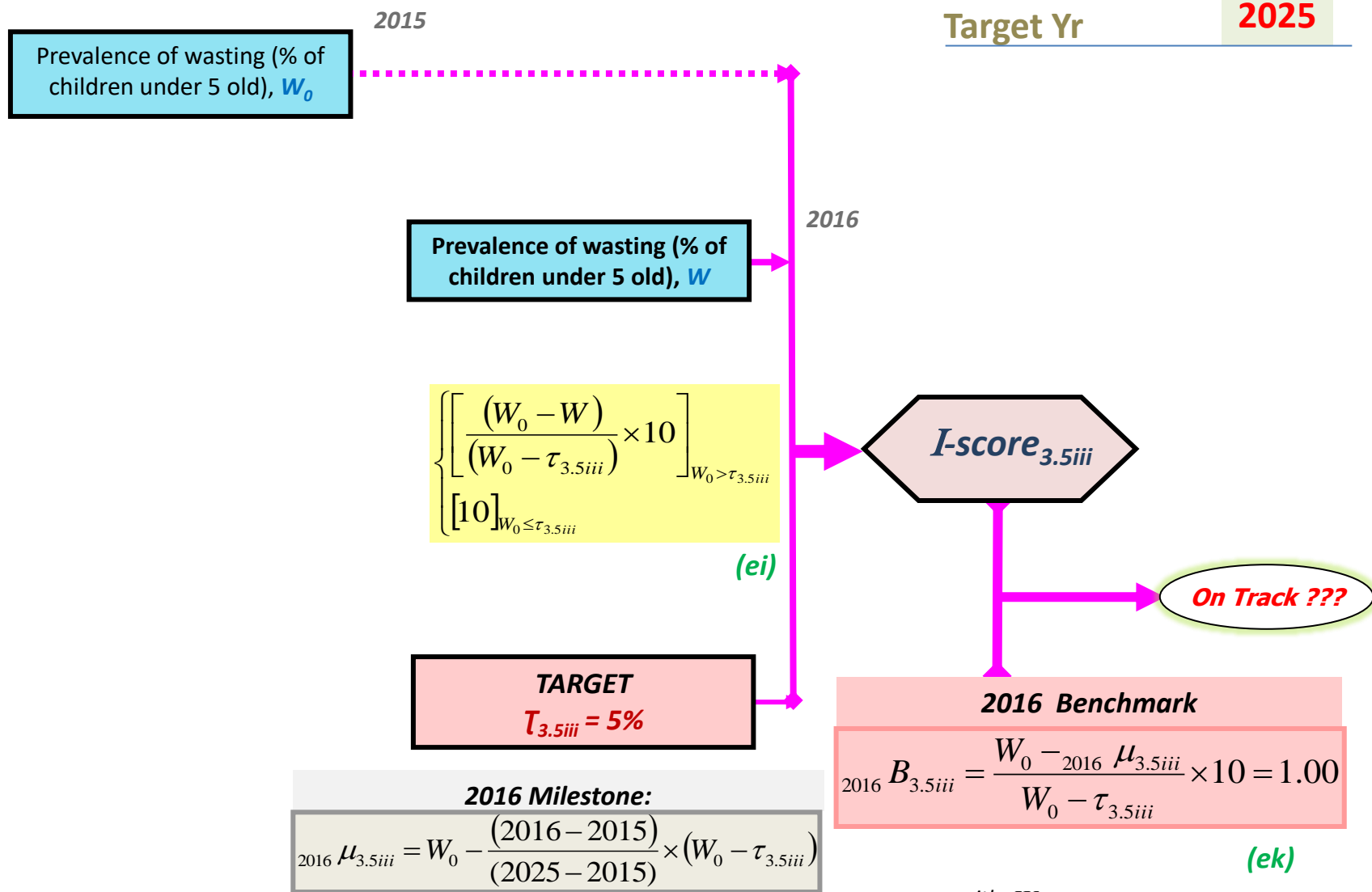

This is a relative milestone which is specific to each country as it depends on where the country is coming from: the 2015 baseline value ... (ej)

... with $W_0 > \tau_{3.5iii}$

I-score_{3.5iv} Estimating progress on prevalence of undernourishment

Baseline Yr	2015
Target Yr	2025

2015
Proportion of the population that is undernourished (% of the country's population), U_0

2016
Proportion of the population that is undernourished (% of the country's population), U

$$\begin{cases} \left[\frac{(U_0 - U)}{(U_0 - \tau_{3.5iv})} \times 10 \right]_{U_0 > \tau_{3.5iv}} \\ [10]_{U_0 \leq \tau_{3.5iv}} \end{cases}$$

(el)

TARGET
 $\tau_{3.5iv} = 5\%$

2016 Milestone:

$${}_{2016} \mu_{3.5iv} = U_0 - \frac{(2016 - 2015)}{(2025 - 2015)} \times (U_0 - \tau_{3.5iv})$$

(em)

I-score_{3.5iv}

On Track ???

2016 Benchmark

$${}_{2016} B_{3.5iv} = \frac{U_0 - {}_{2016} \mu_{3.5iv}}{U_0 - \tau_{3.5iv}} \times 10 = 1.00$$

(en)

... with $U_0 > \tau_{3.5iv}$

This is a relative milestone which is specific to each country as it depends on where the country is coming from: the 2015 baseline value ...

I-score_{3.5v} | Estimating progress on Minimum Dietary Diversity-Women

Baseline Yr	2015
Target Yr	2025

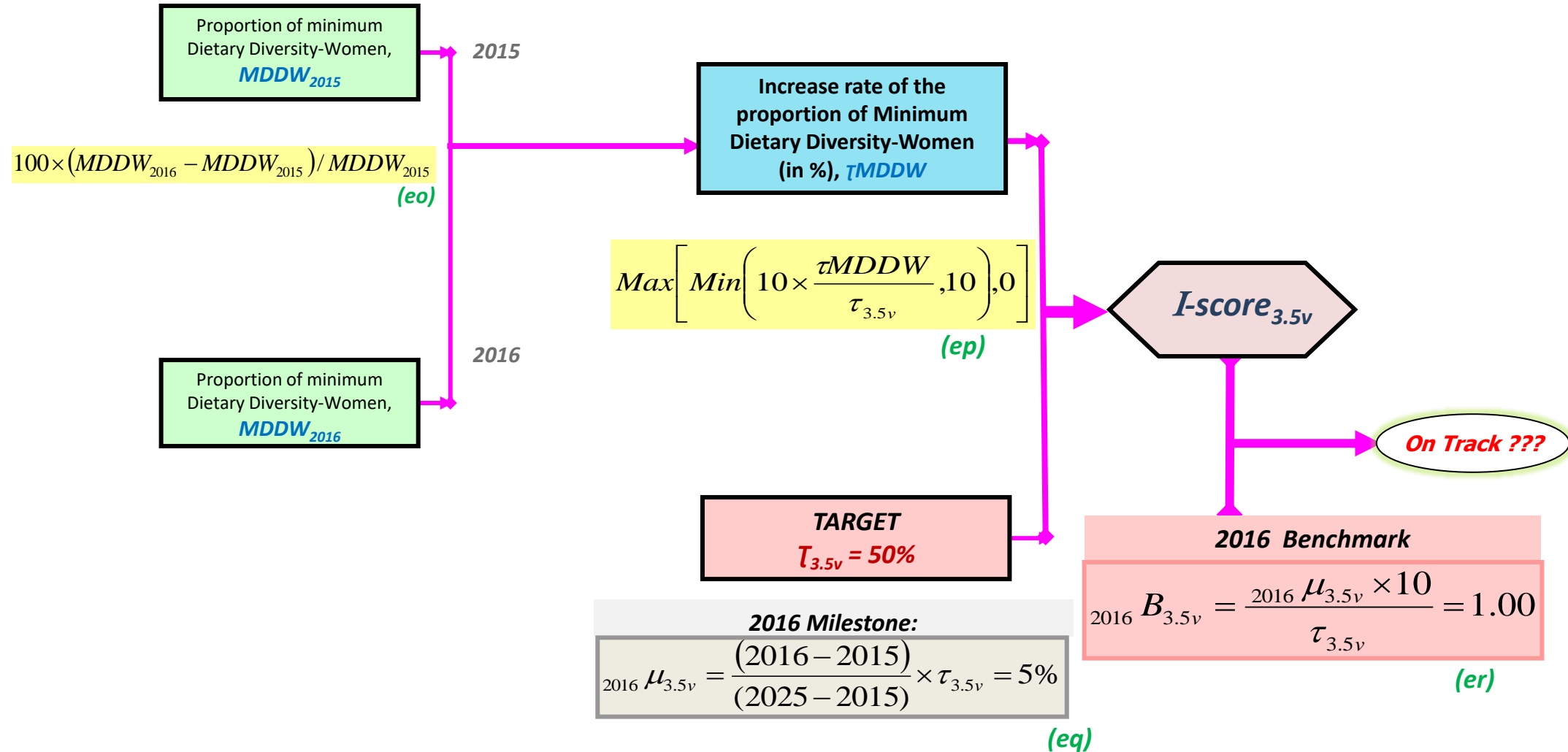

I-score_{3.5vi} | Estimating progress on child Minimum Acceptable Diet

Baseline Yr	2015
Target Yr	2025

2015
Proportion of 6-23 months old children who meet the Minimum Acceptable Diet, MAD_0

2016
Proportion of 6-23 months old children who meet the Minimum Acceptable Diet, MAD

$$\begin{cases} \left[\frac{(MAD - MAD_0)}{(\tau_{3.5vi} - MAD_0)} \times 10 \right]_{MAD_0 < \tau_{3.5vi}} \\ [10]_{MAD_0 \geq \tau_{3.5vi}} \end{cases}$$

(es)

$I\text{-score}_{3.5vi}$

On Track ???

TARGET
 $\tau_{3.5vi} = 50\%$

2016 Benchmark

$${}_{2016} B_{3.5vi} = \frac{{}_{2016} \mu_{3.5vi} - MAD_0}{\tau_{3.5vi} - MAD_0} \times 10 = 1.00$$

(eu)

2016 Milestone:

$${}_{2016} \mu_{3.5vi} = MAD_0 + \frac{(2016 - 2015)}{(2025 - 2015)} \times (\tau_{3.5vi} - MAD_0)$$

(et)

This is a relative milestone which is specific to each country as it depends on where the country is coming from: the 2015 baseline value ...

... with $MAD_0 < \tau_{3.5vi}$

C-score_{3.5} | Combined progress on Food security and Nutrition

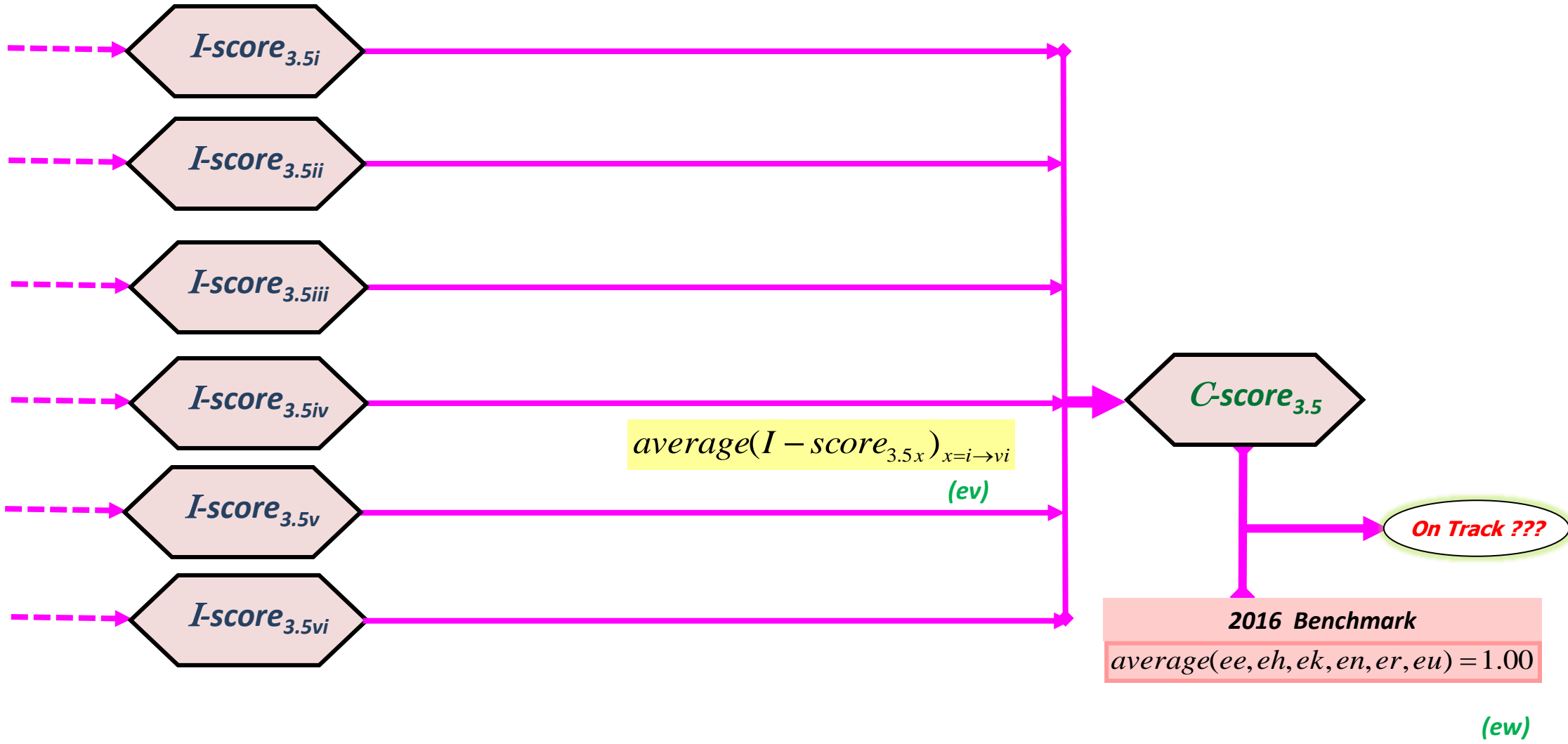

T-score₃ | Overall progress for Theme 3: "ENDING HUNGER"

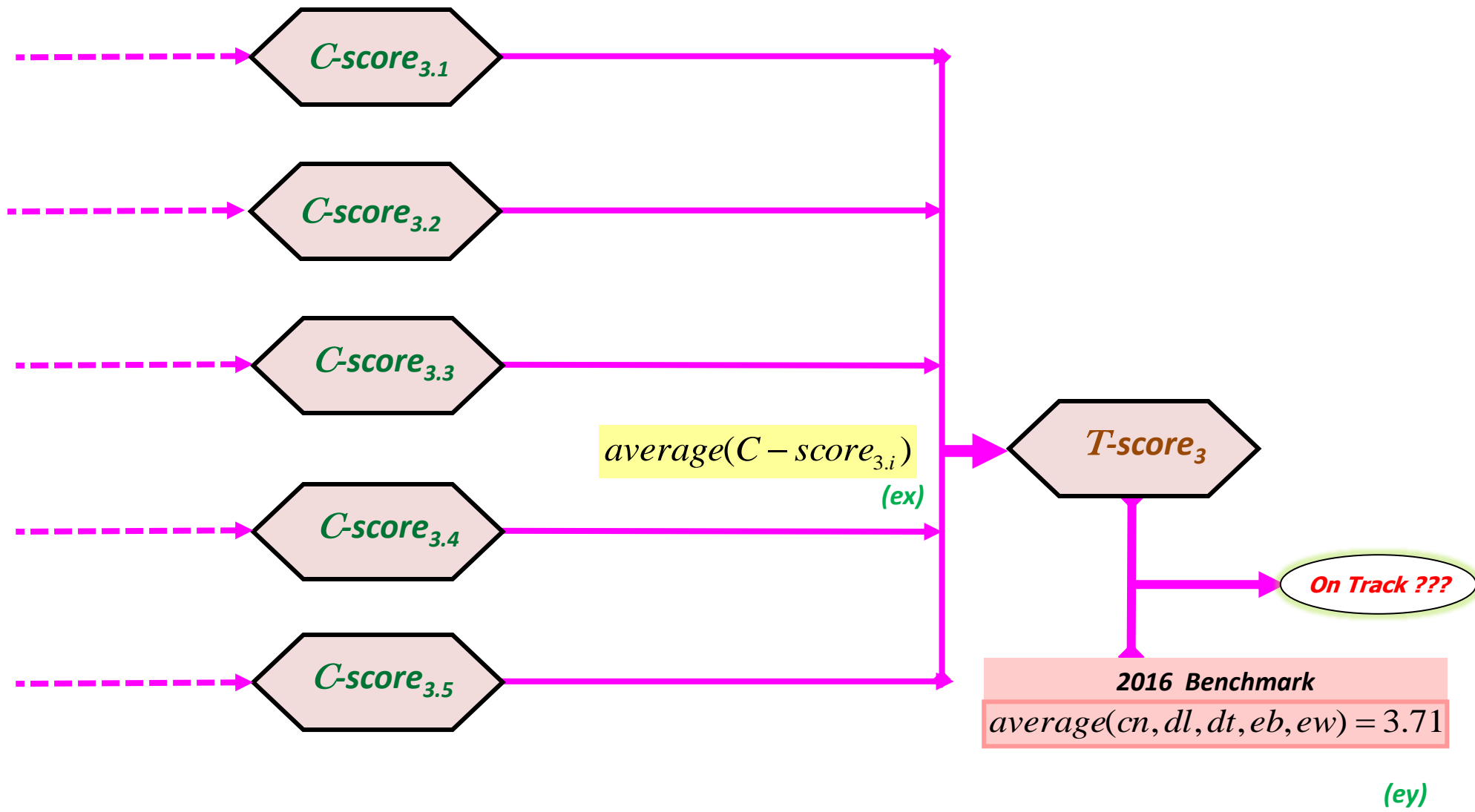



Technical Notes 4

**Performance Evaluation for achieving goals under Theme 4 :
“ERADICATING POVERTY THROUGH AGRICULTURE”**



PC 4.1 | Agricultural GDP and Poverty Reduction

4.1i- Sustain annual agricultural GDP growth of at least 6%, from 2015 to 2025.

4.1ii- Ensure that agriculture growth contribute to at least 50% to the overall poverty reduction target, from 2015 to 2025.

4.1iii- Reduce poverty level by at least 50%, at national poverty line, from 2015 to 2025.

PC 4.1 | Agricultural GDP and Poverty Reduction

4.1iv- Reduce poverty level by at least 50%, at international poverty line, from 2015 to 2025.

4.1v- Contribute to poverty reduction by reducing the gap between the wholesale price and farm-gate price, by 50% , by 2025, from 2015.

I-score_{4.1i} | Estimating progress on agricultural GDP growth

Baseline Yr	2015
Target Yr	2025

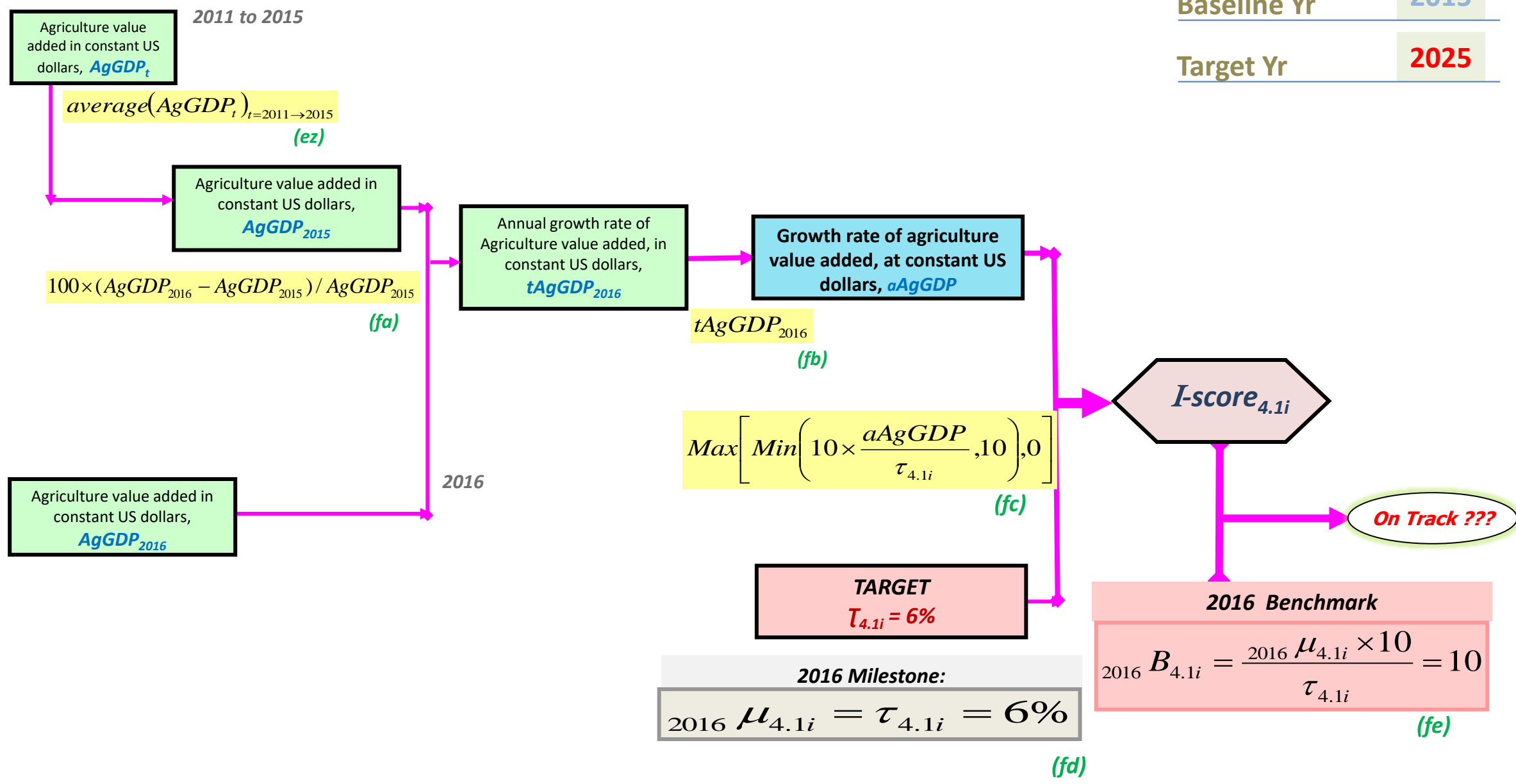

I-score_{4.1ii} | Estimating progress on agriculture growth contribution to the overall poverty reduction target

Baseline Yr	2015
Target Yr	2025

Stand-by for more research

I-score_{4.1iii} | Estimating progress on poverty reduction at national poverty line

Baseline Yr	2015
Target Yr	2025

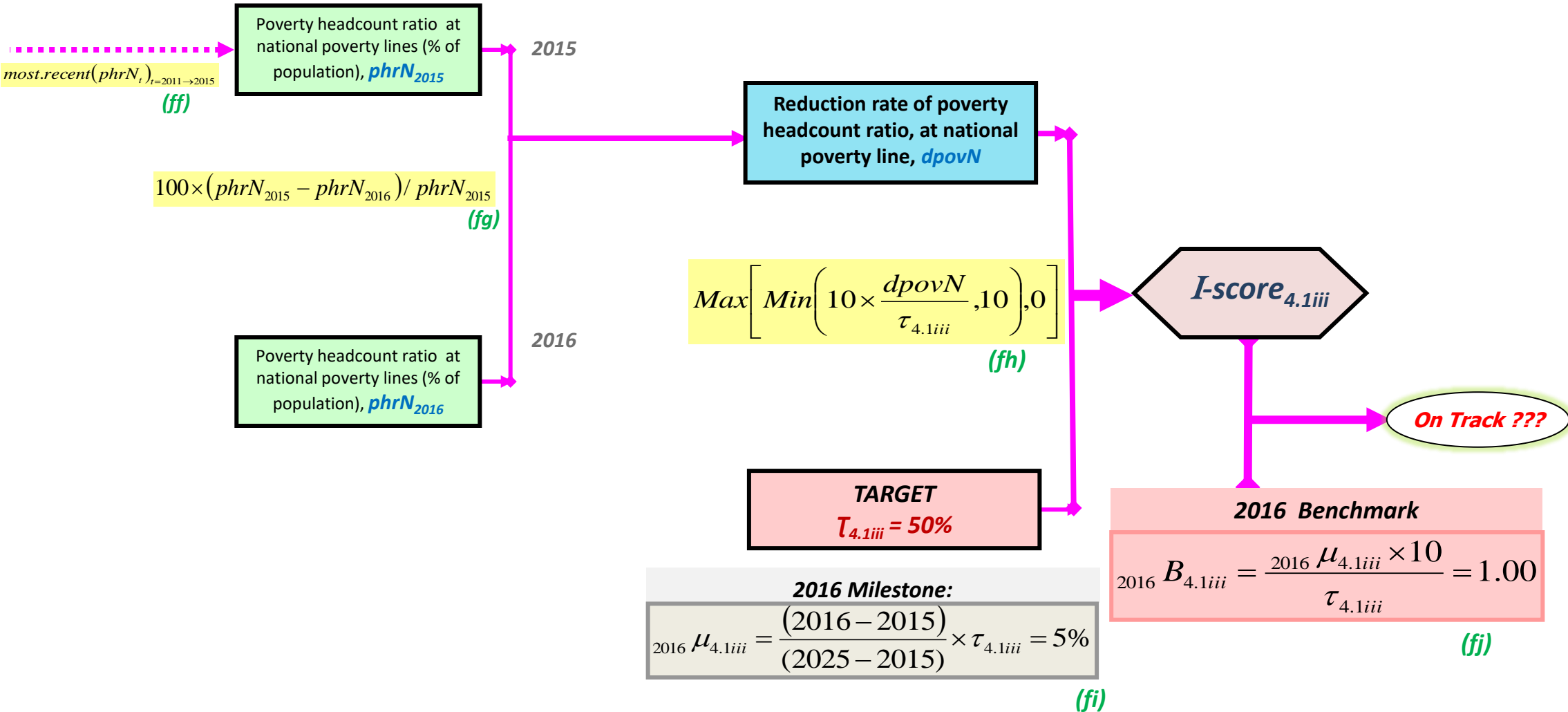

I-score_{4.1iv} | Estimating progress on poverty reduction at international poverty line

Baseline Yr	2015
Target Yr	2025

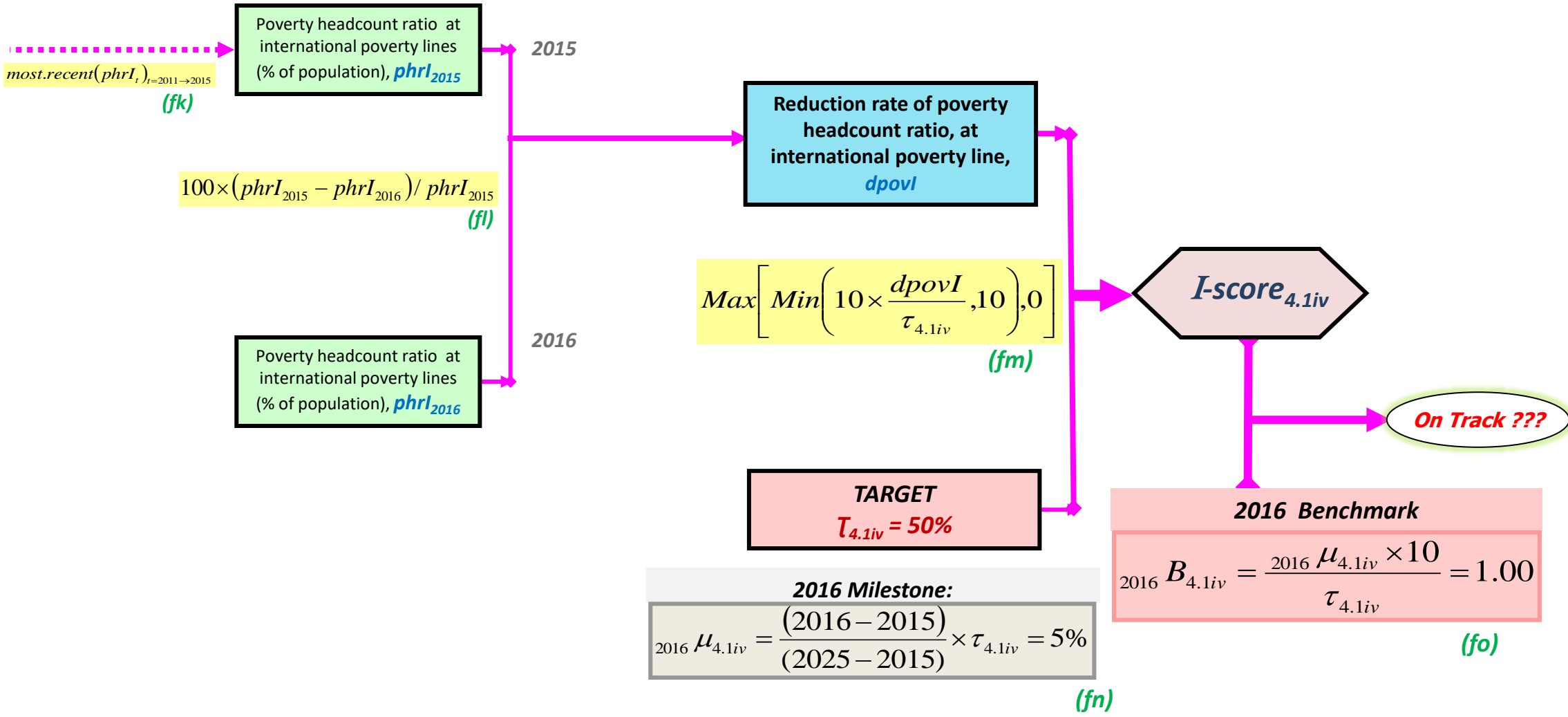

I-score_{4.1v} | Estimating progress on wholesale-farmgate price gap

Baseline Yr	2015
Target Yr	2025

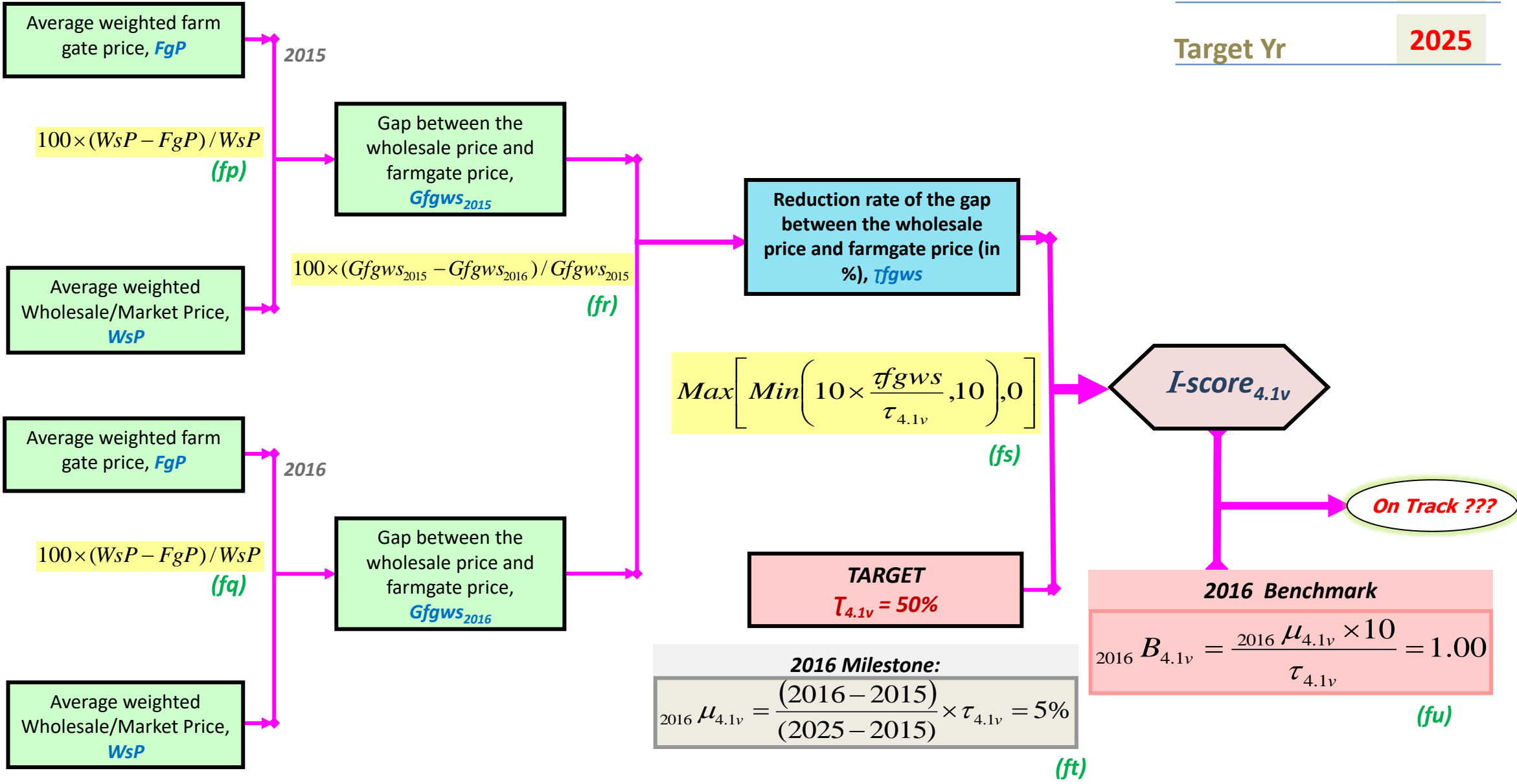

C-score_{4.1} | Combined progress on Agricultural GDP and Poverty Reduction

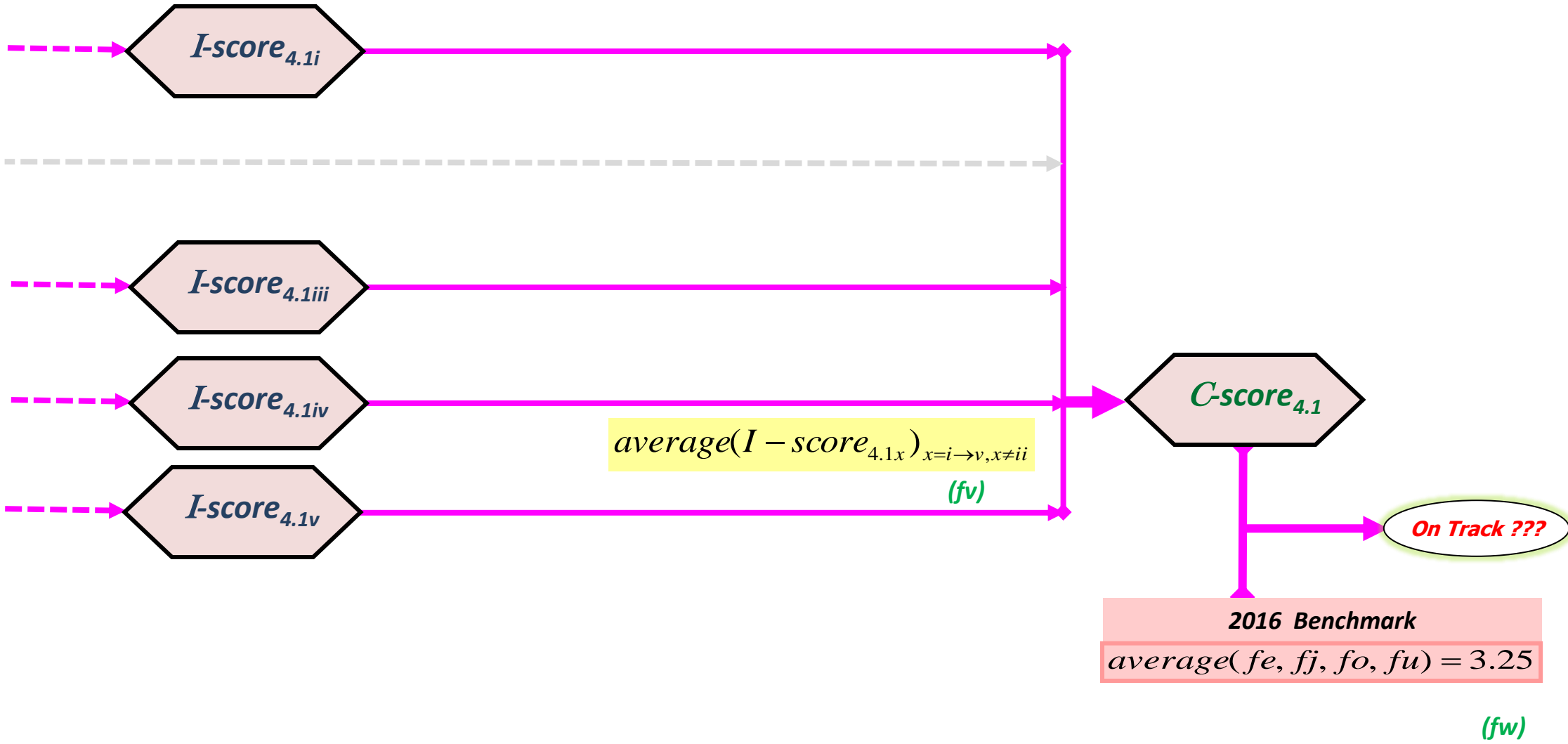

PC 4.2 | Inclusive PPPs for commodity value chains

4.2- Establish and/or strengthen inclusive public-private partnerships (PPP) for at least five (5) priority agricultural commodity value chains with strong linkage to smallholder agriculture, by 2025.

I-score_{4.2} | Estimating progress on priority agricultural commodity value chains that involve smallholder agriculture

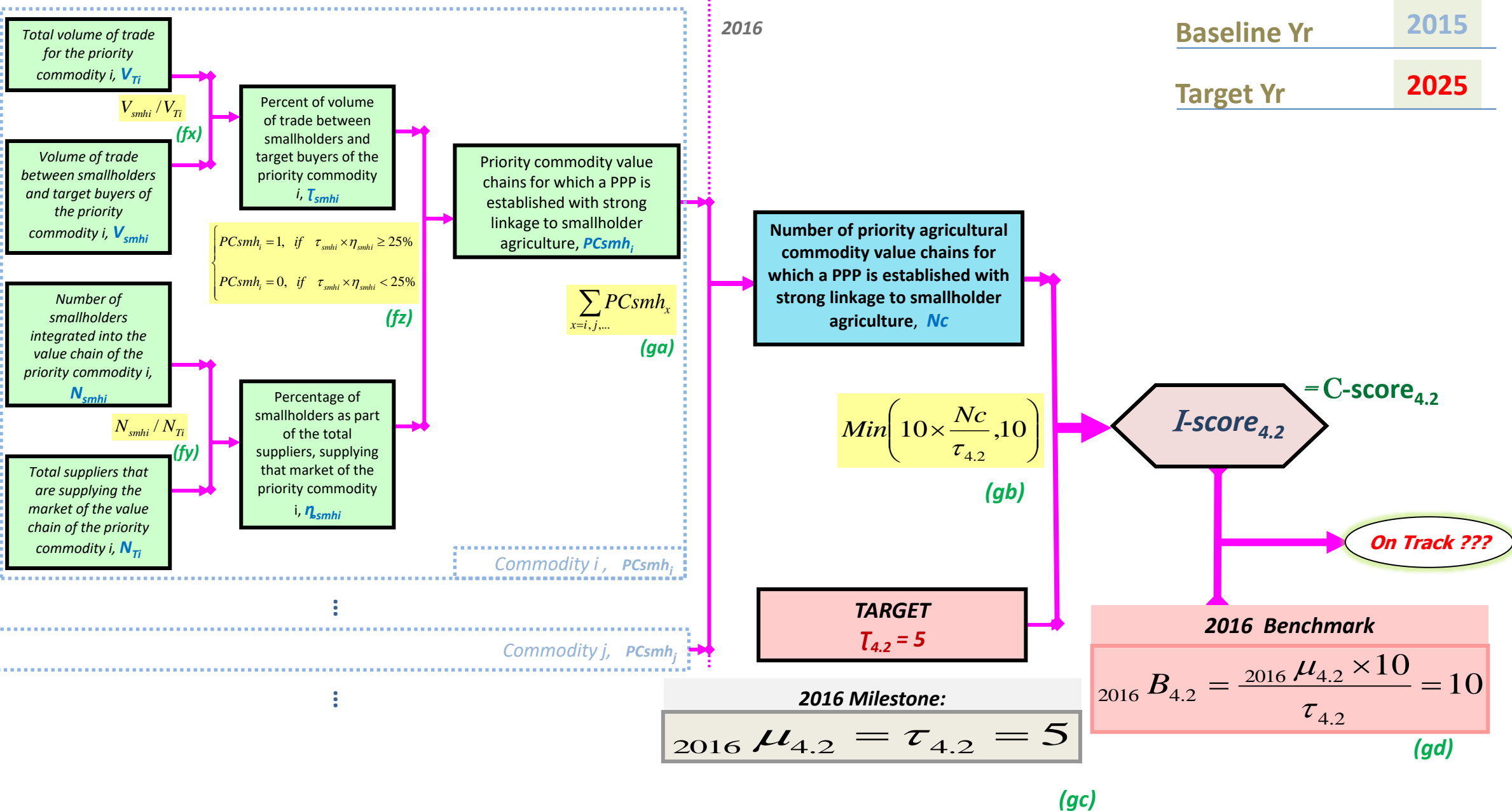

PC 4.3 | Youth job in agriculture

4.3- Create job opportunities for at least 30% of the youth in agricultural value chains, by 2025.



I-score_{4.3} | Estimating progress on Youth job in agriculture

Baseline Yr	2015
Target Yr	2025

 Cumulative number of new jobs for youth, counted from the year 2015.

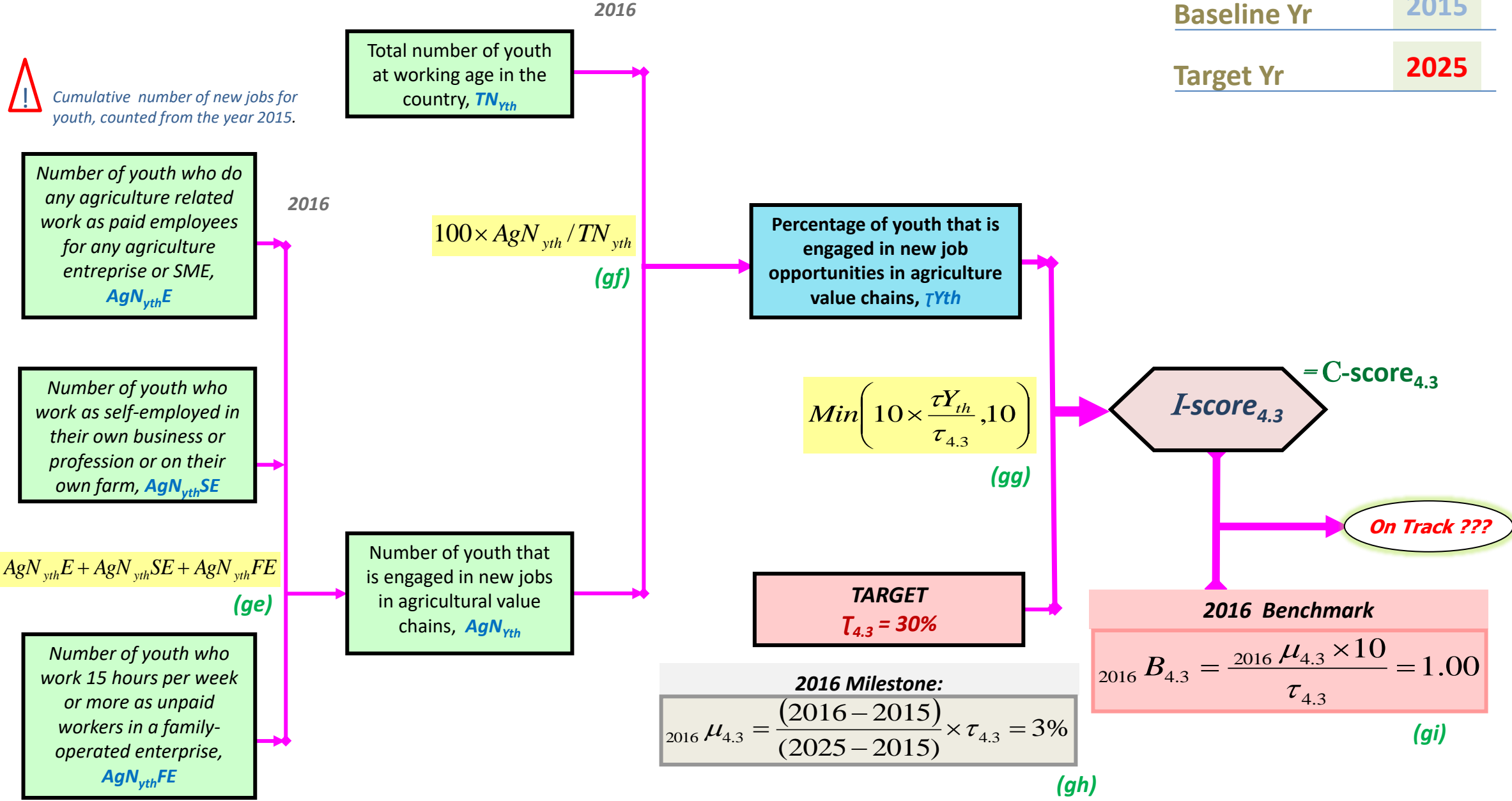

PC 4.4 | Women participation in Agriculture

4.4- Ensure that 20% of rural women have access to productive assets, including land, credit, inputs and financial services and information (empowered) by 2023.



I-score_{4.4} | Estimating progress on Women Empowerment in agriculture

Baseline Yr	2013
Target Yr	2023

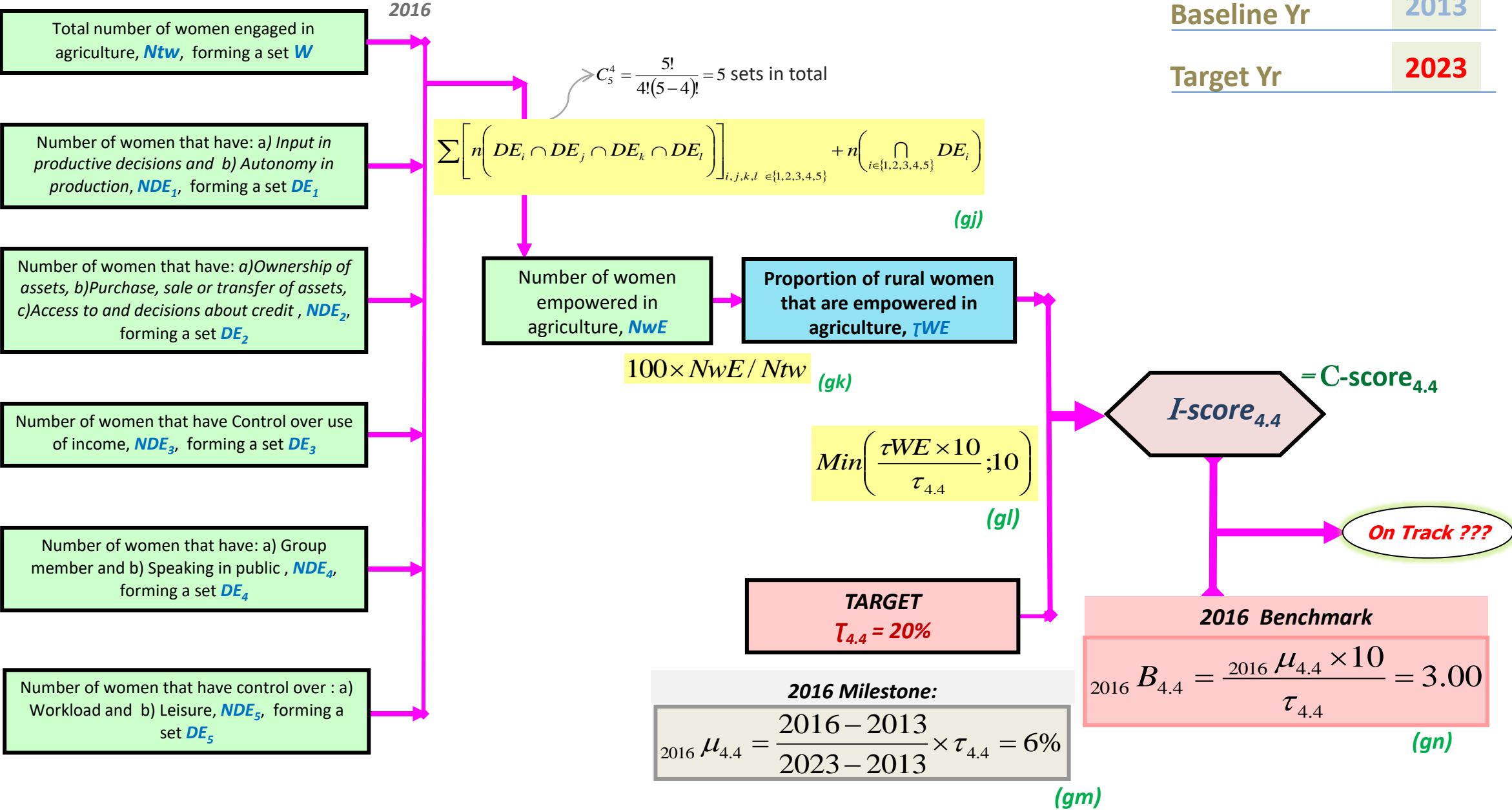

T-score₄ | Overall progress for Theme 4: "ERADICATING POVERTY THROUGH AGRICULTURE"

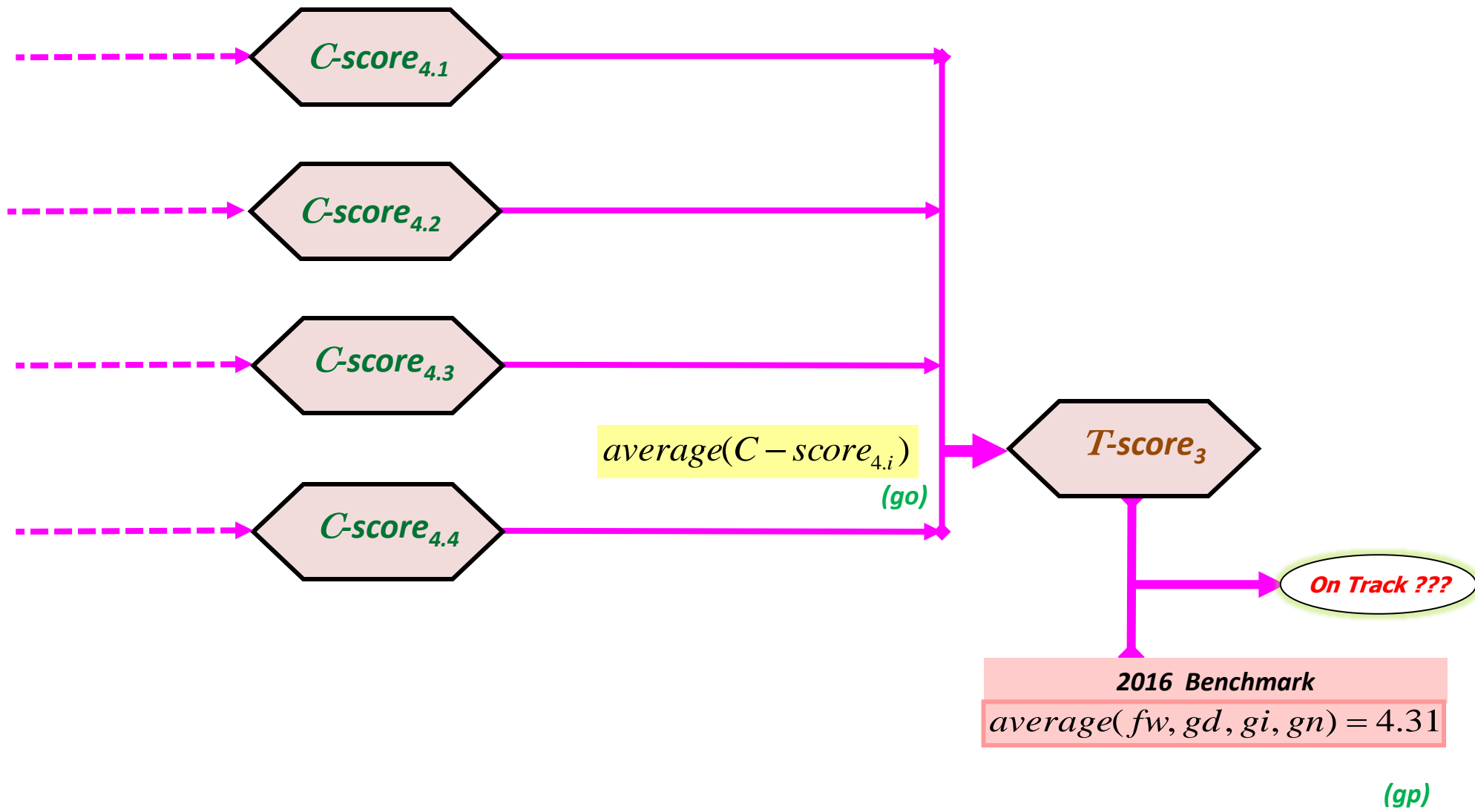



Technical Notes 5

**Performance Evaluation for achieving goals under Theme 5 :
“INTRA-AFRICAN TRADE IN AGRICULTURE COMMODITIES”**



PC 5.1 | Intra-African Trade in agriculture commodities and services

5.1- Triple intra-African trade in agricultural commodities and services, by 2025 from 2015.

I-score_{5.1} | Estimating progress on Intra-African Trade for agriculture commodities and services

Baseline Yr	2015
Target Yr	2025

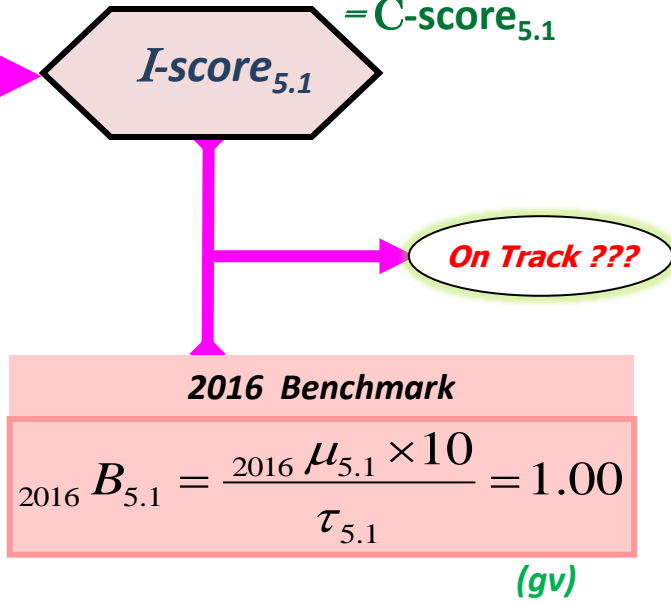
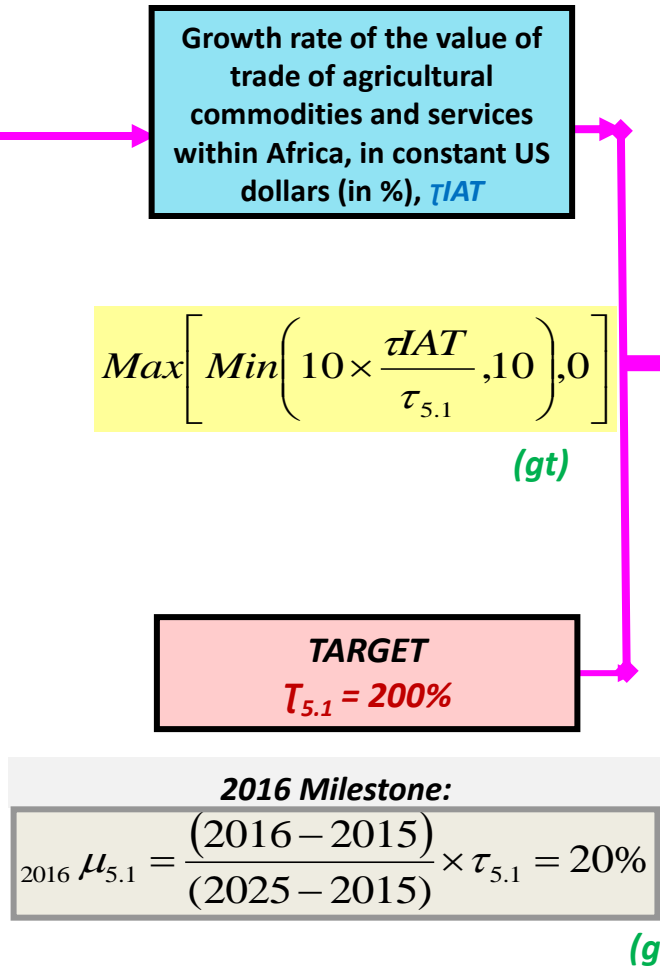
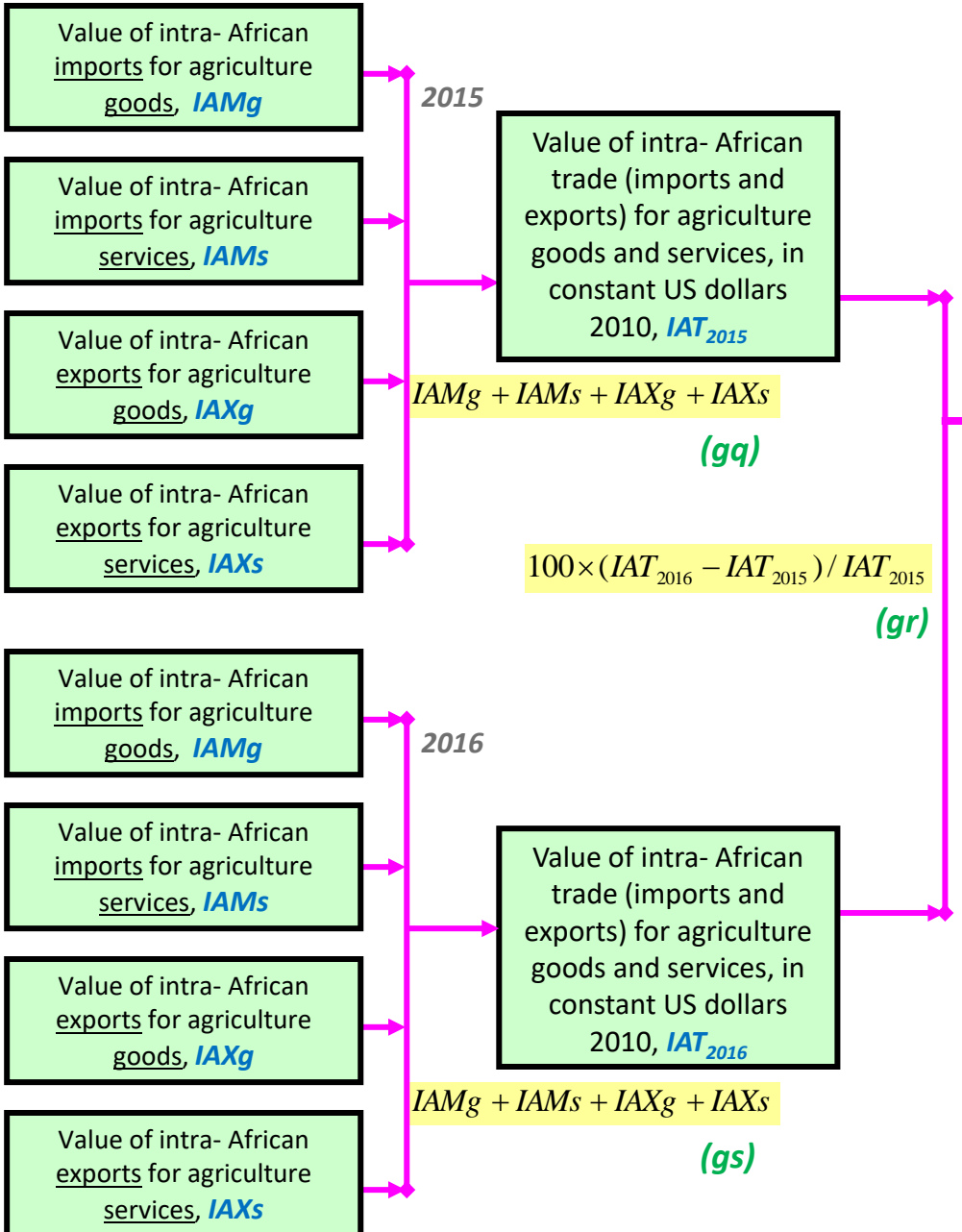

PC 5.2 | Intra-African Trade Policies and institutional conditions

5.2i- Fully establish trade facilitation measures by reaching 100% of Trade Facilitation Index by 2025.

5.2ii- Reduce the Domestic Food Price Volatility Index to less than 7.5% by 2025.

I-score_{5.2i} | Estimating progress on Trade Facilitation

Baseline Yr	2015
Target Yr	2025

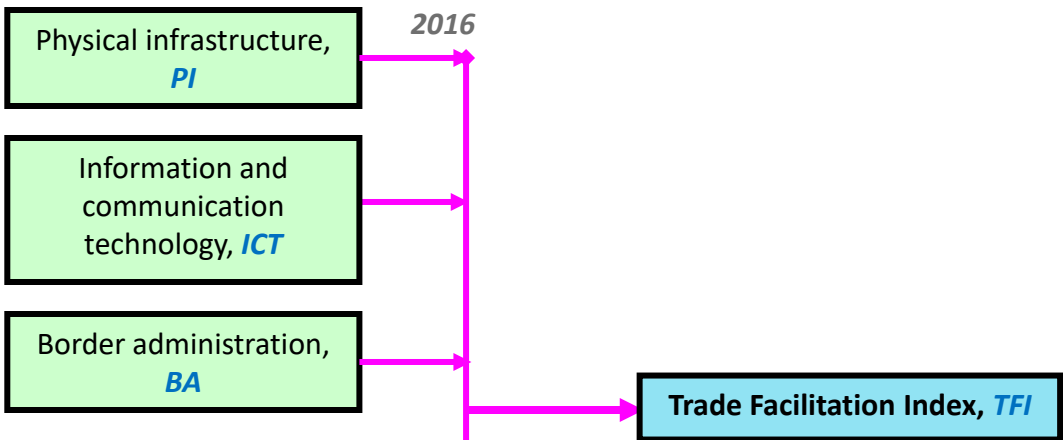

$$\frac{(PI + ICT + BA + ATA + IM)}{5} \quad (gy)$$

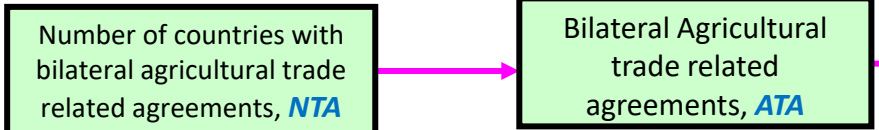

$$\frac{NTA}{54} \times 100 \quad (gw)$$

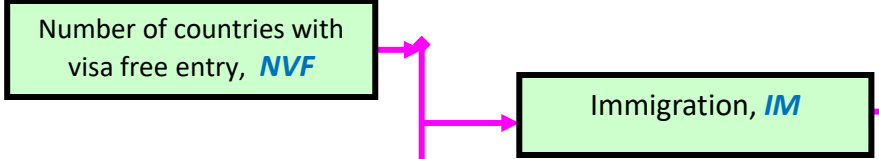

$$\frac{(NVF + VA)}{54} \times 100 \quad (gx)$$

$$\frac{TFI \times 10}{\tau_{5.2i}} \quad (gz)$$



On Track ???

TARGET
*τ*_{5.2i} = 100%

2016 Milestone:

$${}_{2016} \mu_{5.2i} = \frac{(2016 - 2015)}{(2025 - 2015)} \times \tau_{5.2i} = 10\% \quad (ha)$$

2016 Benchmark

$${}_{2016} B_{5.2i} = \frac{{}_{2016} \mu_{5.2i} \times 10}{\tau_{5.2i}} = 1.00 \quad (hb)$$

I-score_{5.2ii} | Estimating progress on Domestic Food Price Volatility

Baseline Yr	2015
Target Yr	2025

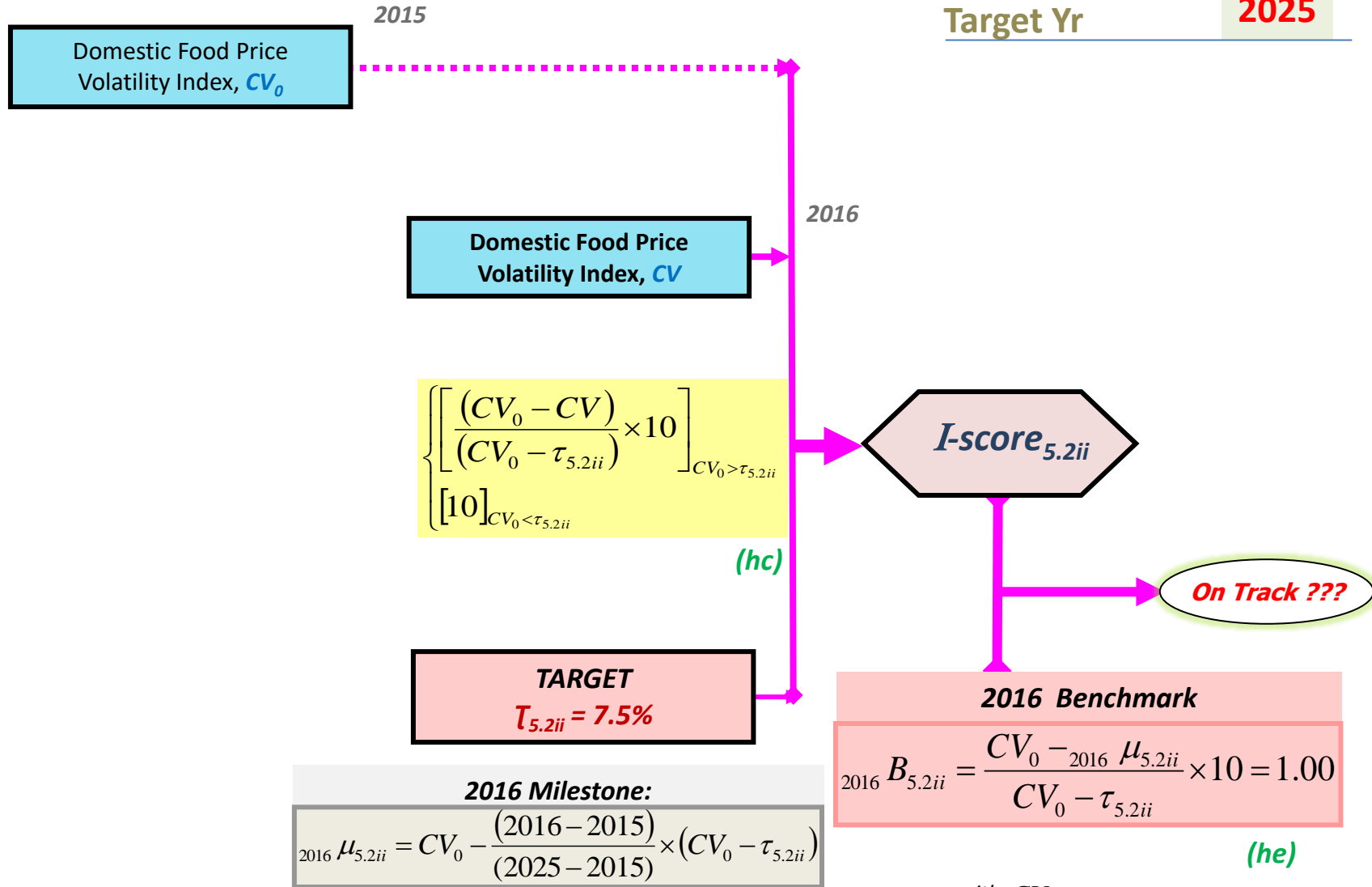

This is a relative milestone which is specific to each country as it depends on where the country is coming from: the 2015 baseline value ... (hd)

... with $CV_0 > \tau_{5.2ii}$

C-score_{5.2} | Combined progress on Intra-African Trade Policies and institutional conditions

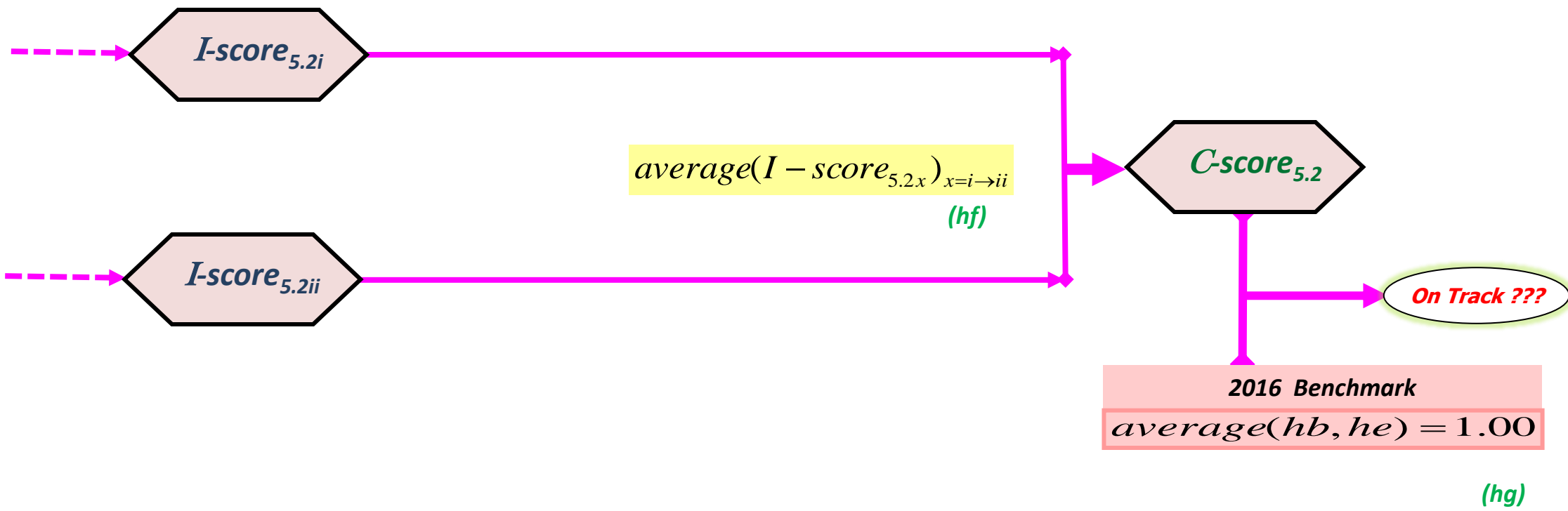

T-score₅ | Overall progress for Theme 5: "INTRA-AFRICAN TRADE IN AGRICULTURE COMMODITIES"

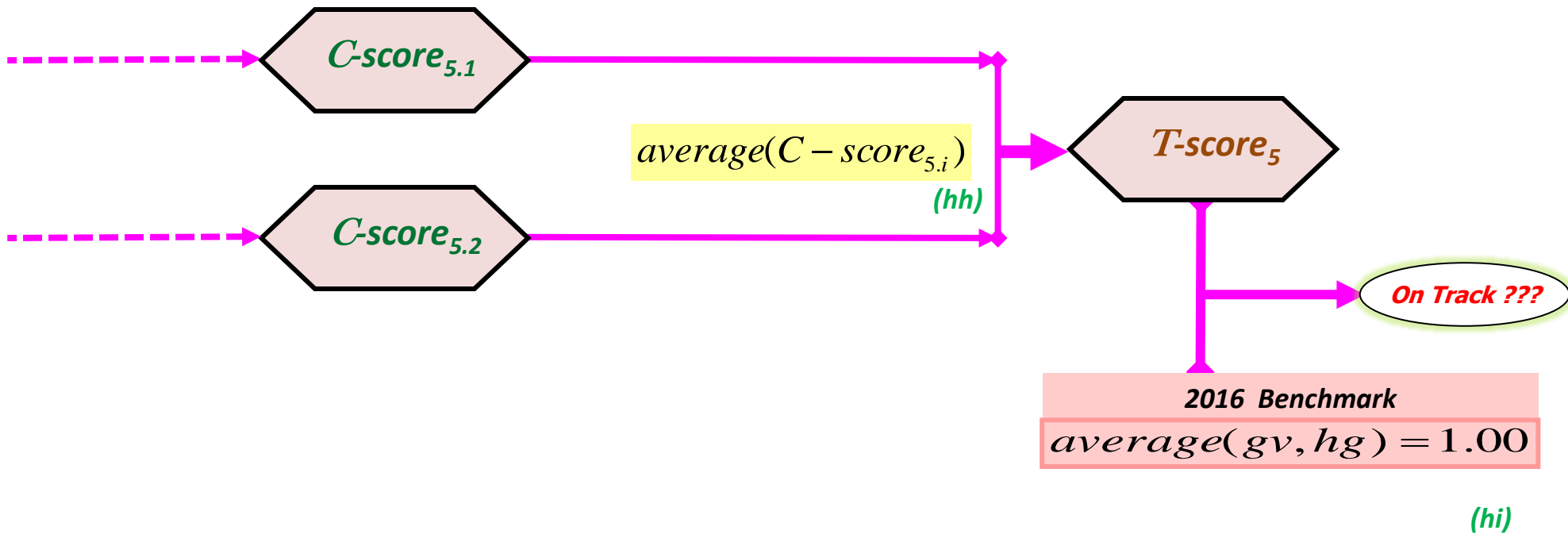



Technical Notes 6

**Performance Evaluation for achieving goals under Theme 6 :
“RESILIENCE TO CLIMATE VARIABILITY”**



PC 6.1 | Resilience to climate related risks

6.1i- Ensure that at least 30% of farm, pastoral, and fisher households are resilient to climate and weather related risks, by 2025.

6.1ii- Ensure that at least 30% of agricultural land is placed under sustainable land management practice by 2023 from 2013.

I-score_{6.1i} | Estimating progress on households resilience to climate and weather related risks

Baseline Yr	2015
Target Yr	2025

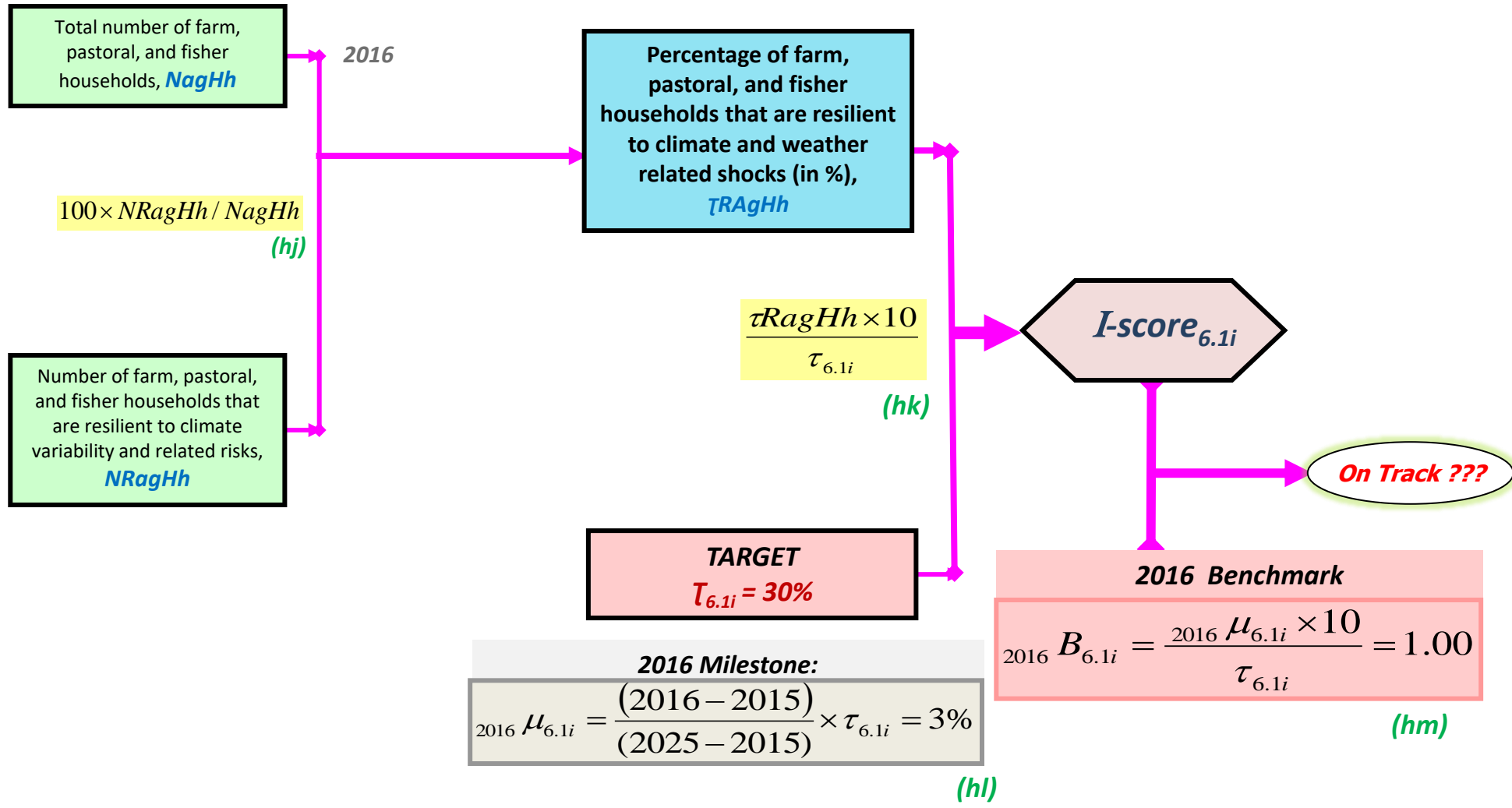

I-score_{6.1ii} | Estimating progress on sustainable land management

Baseline Yr	2013
Target Yr	2023

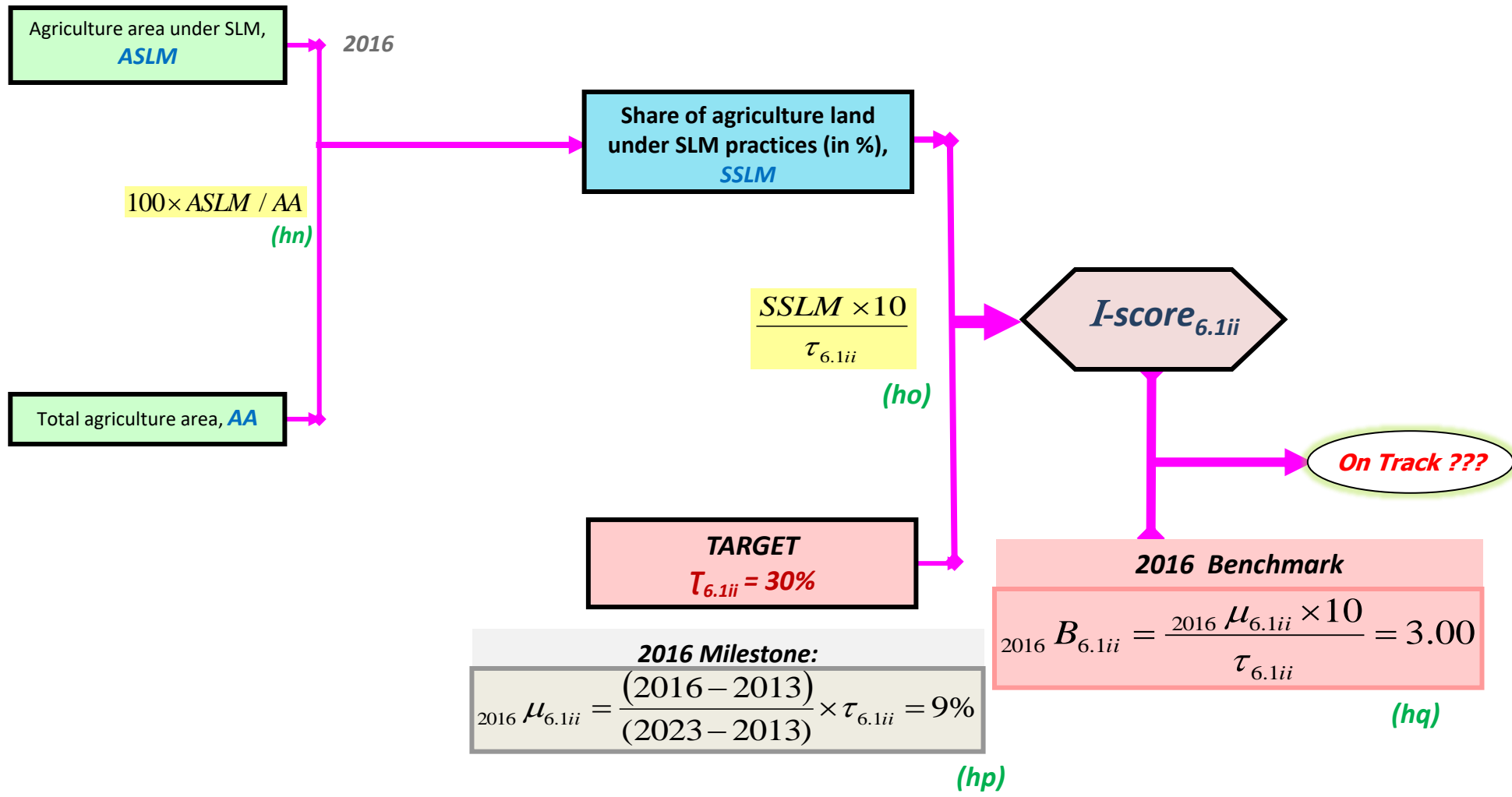

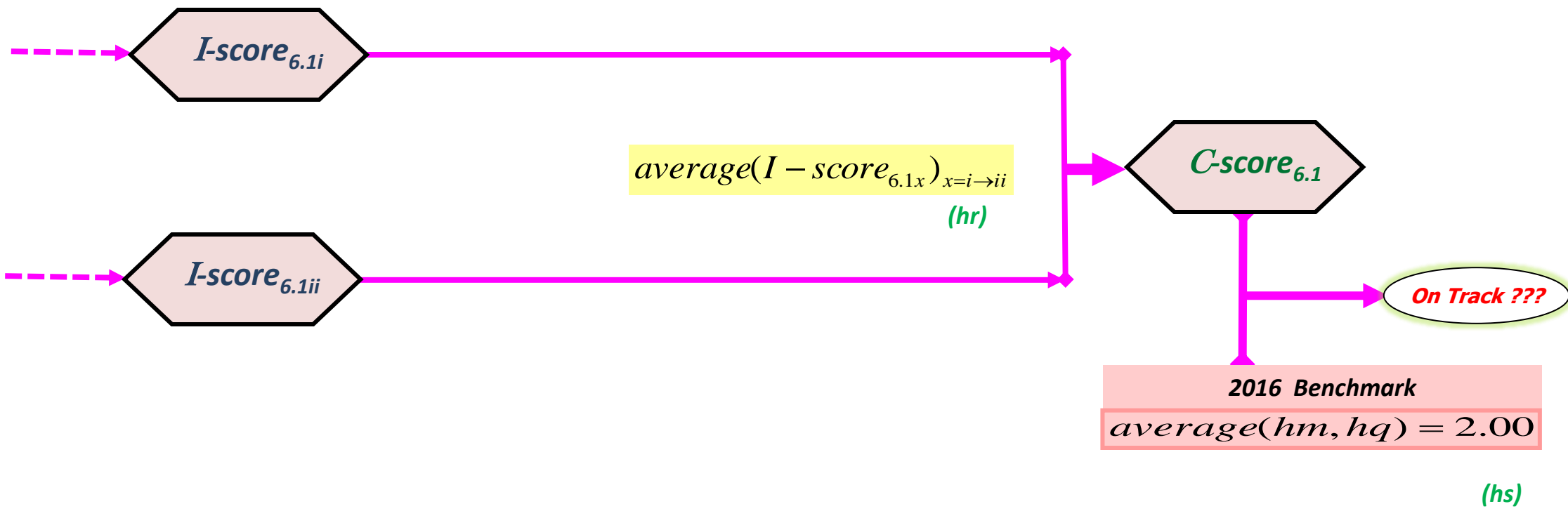

PC 6.2 | Investment in resilience building

6.2- Create permanent investment budget-lines to respond to spending needs on resilience building initiatives, especially for disaster preparedness plans, functioning early warning and response systems, social safety nets, and weather-based index insurance, from 2015 to 2025.

I-score_{6.2} | Estimating progress on availability of budget lines on resilience building

Baseline Yr	2015
Target Yr	2025

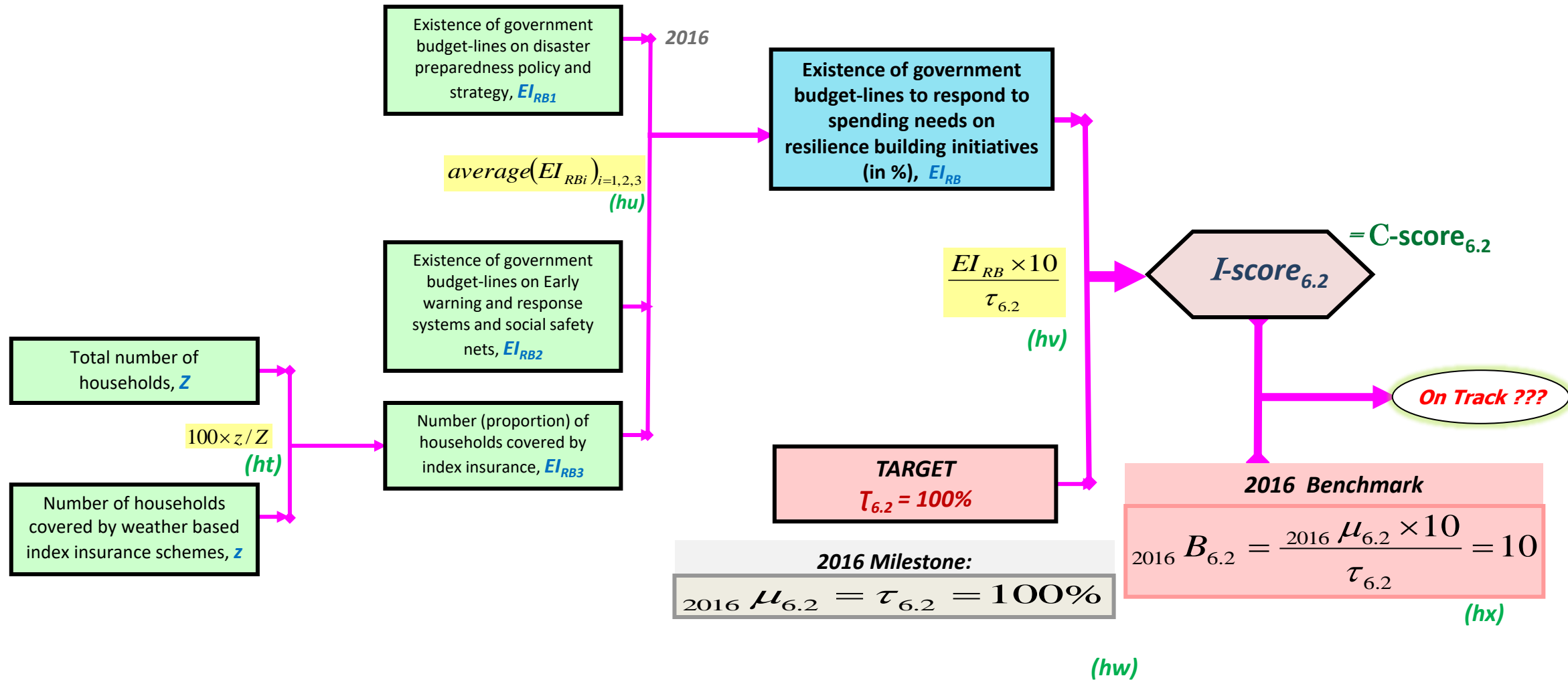

T-score₆ | Overall progress for Theme 6: "RESILIENCE TO CLIMATE VARIABILITY"

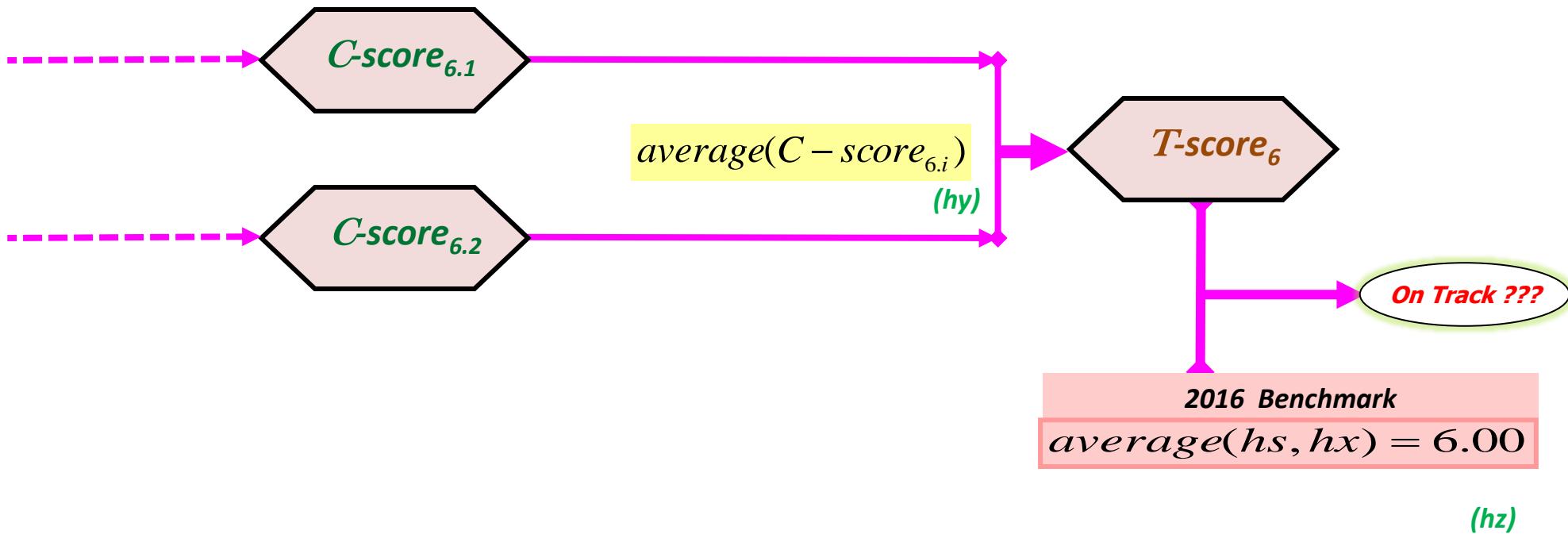



Technical Notes 7

**Performance Evaluation for achieving goals under Theme 7 :
“MUTUAL ACCOUNTABILITY FOR ACTIONS AND RESULTS”**



PC 7.1 | Country capacity for evidence based planning, implementation and M&E

7.1- Reach at least 63 for the Index of capacity to generate and use agriculture statistical data and information (ASCI), by 2025. 2015.



I-score_{7.1} | Estimating progress on the country capacity to generate and use agriculture statistical data

Baseline Yr	2015
Target Yr	2025

2015
Index of capacity to generate and use agriculture statistical data and information, $ASCI_0$

2016
Index of capacity to generate and use agriculture statistical data and information, $ASCI$

$$\begin{cases} \left[\frac{(ASCI - ASCI_0)}{(\tau_{7.1} - ASCI_0)} \times 10 \right]_{ASCI_0 < \tau_{7.1}} \\ [10]_{ASCI_0 \geq \tau_{7.1}} \end{cases}$$

(ia)

TARGET
 $\tau_{7.1} = 63$

2016 Milestone:

$${}_{2016} \mu_{7.1} = ASCI_0 + \frac{(2016 - 2015)}{(2025 - 2015)} \times (\tau_{7.1} - ASCI_0)$$

(ib)

$I\text{-score}_{7.1}$ = C-score_{7.1}

On Track ???

2016 Benchmark

$${}_{2016} B_{7.1} = \frac{{}_{2016} \mu_{7.1} - ASCI_0}{\tau_{7.1} - ASCI_0} \times 10 = 1.00$$

(ic)

... with $ASCI_0 < \tau_{7.1}$

This is a relative milestone which is specific to each country as it depends on where the country is coming from: the 2015 baseline value ...

PC 7.2 | Peer Review and Mutual Accountability

7.2- Foster alignment, harmonization and coordination among multi-sectorial efforts and multi-institutional platforms for peer review, mutual learning and mutual accountability, (reach 100% for the Existence of inclusive institutionalized mechanisms and platforms for mutual accountability and peer review, ECI) by 2018.

I-score_{7.2} | Estimating progress on Peer Review and Mutual Accountability

Baseline Yr	2015
Target Yr	2018

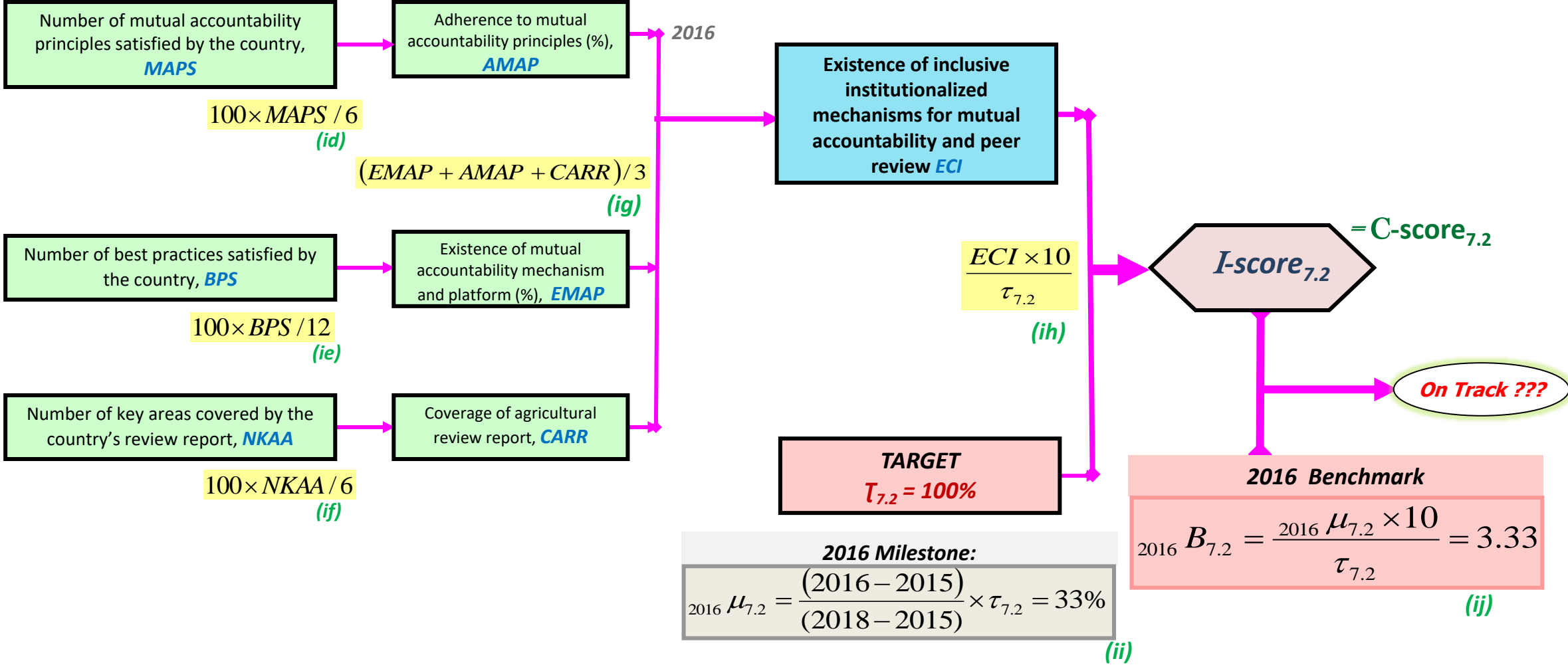

PC 7.3 Biennial Agriculture Review Process

7.3- Conduct a biennial Agriculture Review Process that involves tracking, monitoring and reporting progress made in implementing the Malabo Declaration, by availing the regular country Biennial Report to the AU Assembly.

I-score_{7.3} | Estimating progress on availing the regular country Biennial Report for the AU Assembly

Baseline Yr	2015
Target Yr	2025

- Number of parameters reported by the country, n
 - Total number of parameters reflected in the country reporting format, N

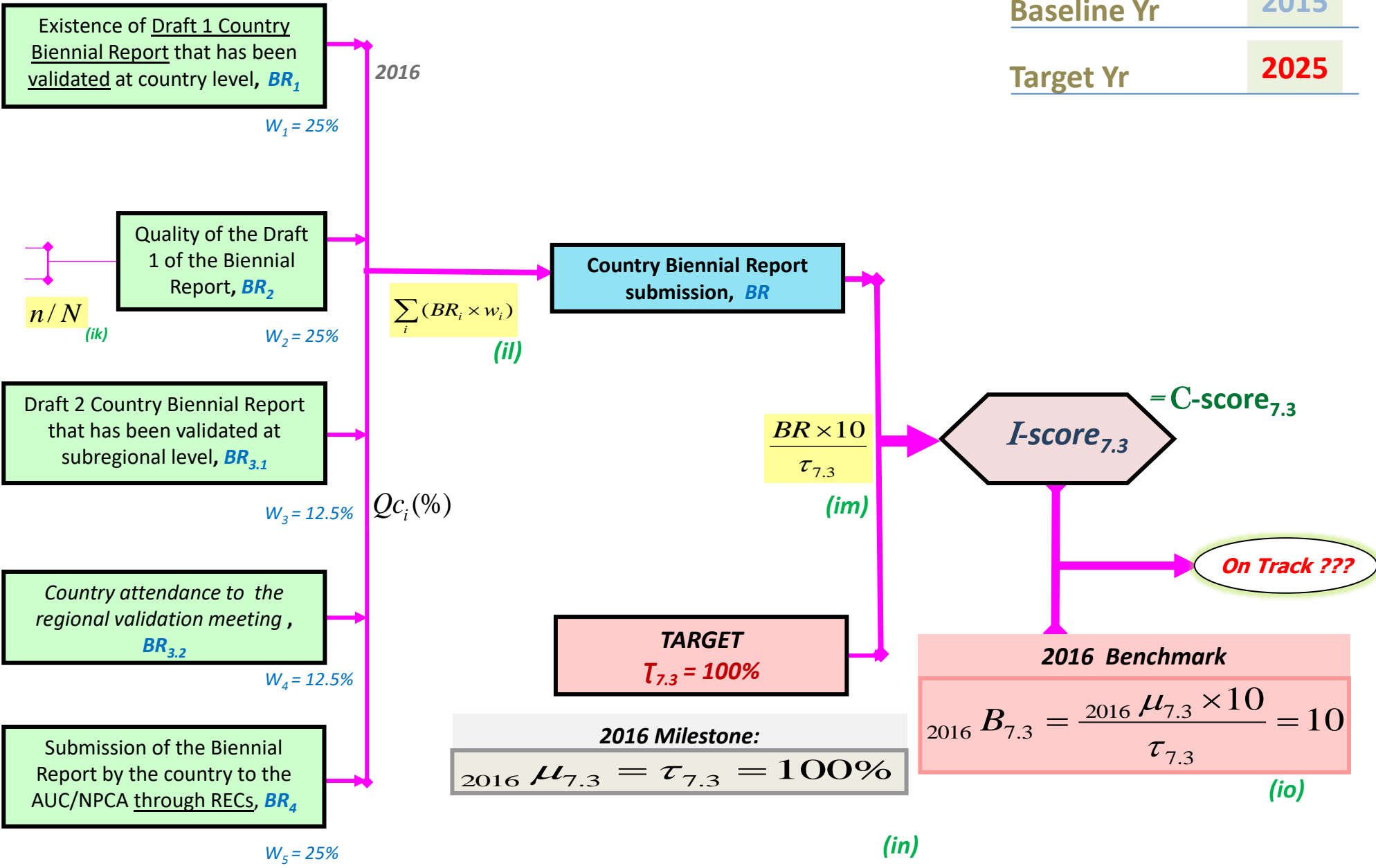

T-score₇ | Overall progress for Theme 7: "MUTUAL ACCOUNTABILITY FOR ACTIONS AND RESULTS"

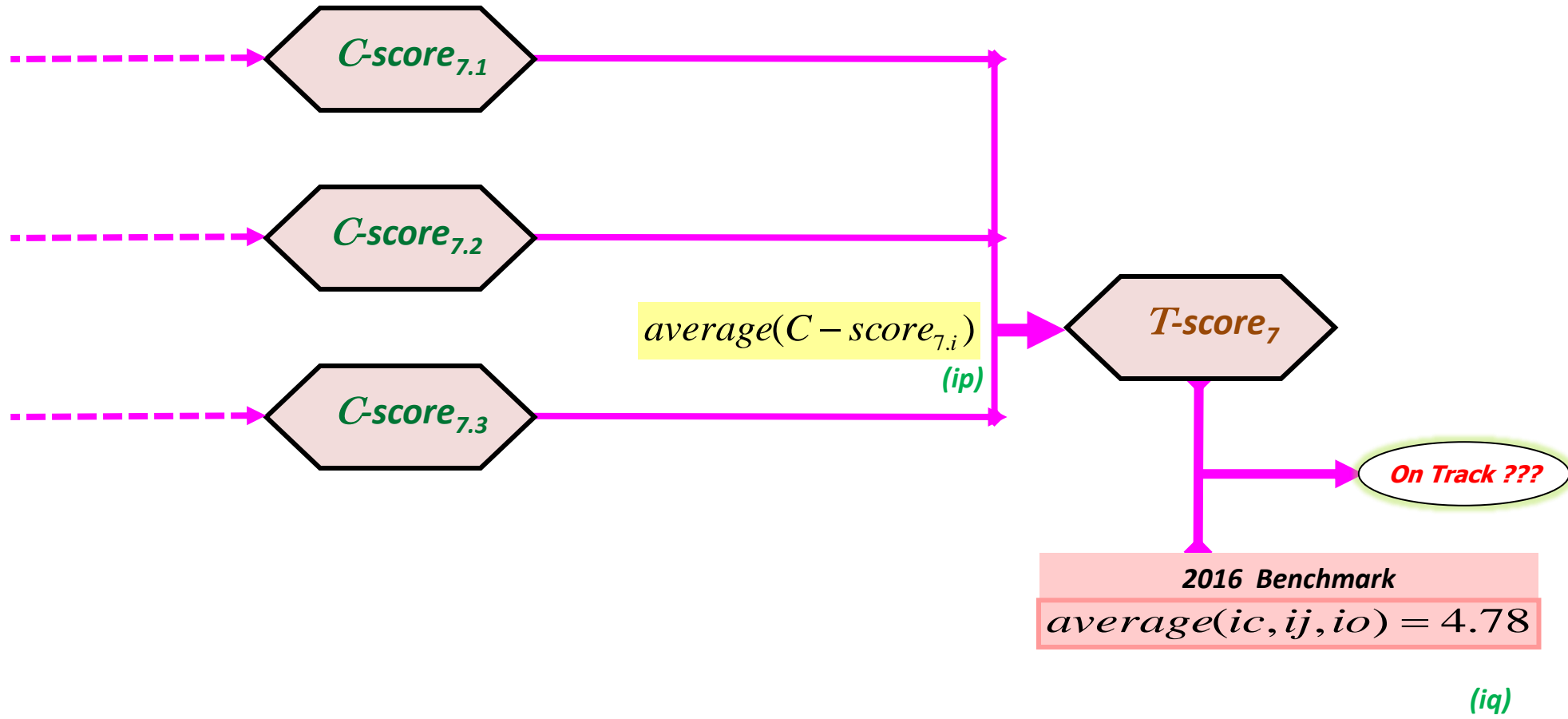

O-score | OVERALL PROGRESS FOR IMPLEMENTING THE JUNE 2014 MALABO DECLARATION ON AFRICAN AGRICULTURE TRANSFORMATION

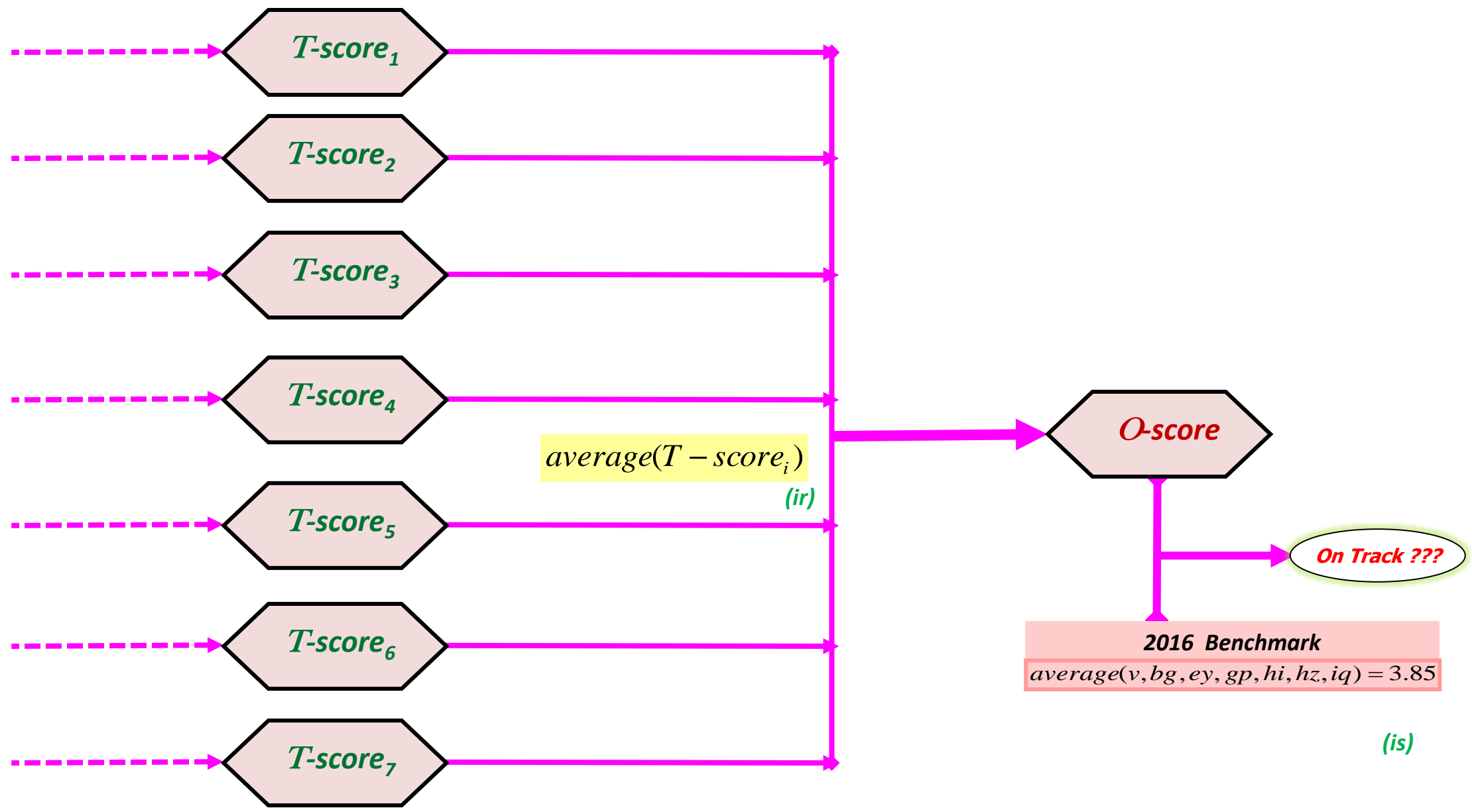

The 2017 Benchmark Scorecard

on Country performances in implementing Malabo Declaration for agricultural transformation in Africa...

... minimum scores to be on track in 2017 for meeting targets set for each of the 7 commitments of the Malabo Declaration.

Temporary Structure of the Country Scorecard proposed @ the Experts Group Reflection Meeting on Scorecard held on 3rd-5th August 2016 in Nairobi, Kenya.

The 2017 Malabo Benchmark Scorecard					
Performance Theme			Performance Category		
No.	Item	T-score	No.	Item	C-score
1	Commitment to CAADP Process	3.3	PC 1.1	National CAADP Process	3.3
			PC 1.2	CAADP based Cooperation, Partnership & Alliance	3.3
			PC 1.3	CAADP based Policy & Institutional Review/ Setting/ Support	3.3
2	Investment Finance in Agriculture	3.8	PC 2.1	Public Expenditures to Agriculture	10
			PC 2.2	Domestic Private Sector Investment in Agric., Agribusiness, Agro-Ind.	1.0
			PC 2.3	Domestic Private Sector Investment in Agric., Agribusiness, Agro-Ind.	1.0
			PC 2.4	Access to finance	3.3
3	Ending Hunger	3.7	PC 3.1	Access to Agriculture inputs and technologies	5.5
			PC 3.2	Agricultural Productivity	1.0
			PC 3.3	Post-Harvest Loss	1.0
			PC 3.4	Social Protection	10
			PC 3.5	Food security and Nutrition	1.0
4	Eradicating Poverty through Agriculture	4.3	PC 4.1	Agricultural GDP for Poverty Reduction	3.3
			PC 4.2	Inclusive PPPs for commodity value chains	10
			PC 4.3	Youth job in agriculture	1.0
			PC 4.4	Women participation in Agri-business	3
5	Intra-African Trade in Agriculture Commodities	1.0	PC 5.1	Intra-African Trade in agriculture commodities and services	1.0
			PC 5.2	Intra-African Trade Policies and institutional conditions	1.0
6	Resilience to Climate Variability	6.0	PC 6.1	Resilience to climate related risks	2.0
			PC 6.2	Investment in resilience building	10
7	Mutual Accountability for Actions and Results	4.8	PC 7.1	Country capacity for evidence based planning, impl. and M&E	1.0
			PC 7.2	Peer Review and Mutual Accountability	3.3
			PC 7.3	Biennial Agriculture Review Process	10
		O-Score	3.9		

CAADP

African Union Commission, Headquarters, Addis Ababa, Ethiopia
Department of Rural Economy and Agriculture (DREA),
Comprehensive African Agriculture Development Programme (CAADP)

Contacts: Anselme Vodounhessi, anselmev@africa-union.org & Maurice Lorka N'Guessan, N'Guessanp@africa-union.org

Acknowledgements to Africa Lead and USAID for availing Technical Expert to support the development of this Technical Notes.